

Lt Board-Level Camera Series™

User's Manual

USB3 Vision – Monochrome & Color Area Scan

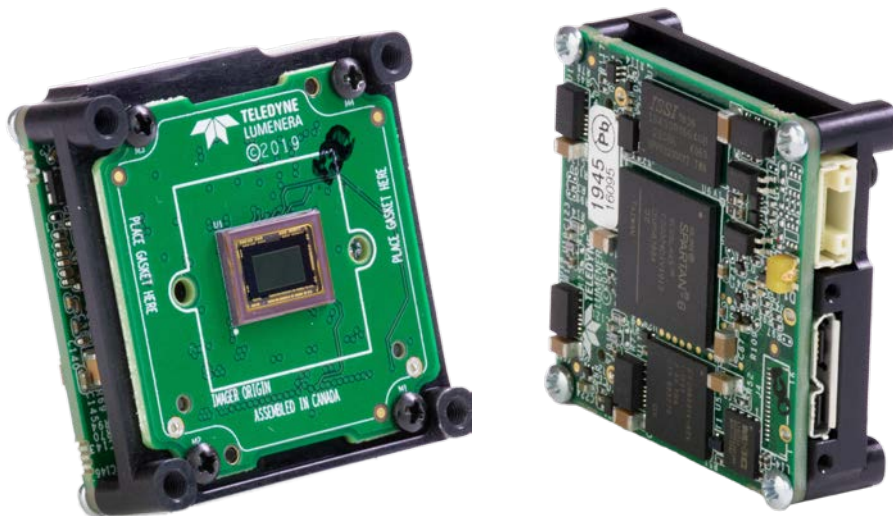

USB™
VISION

June 16, 2021
Rev: 002
P/N: LT-UBLM-USR00
<https://www.lumenera.com/>

 **TELEDYNE LUMENERA**
Everywhere you look™

Notice

© 2021 Teledyne Lumenera

All information provided in this manual is believed to be accurate and reliable. No responsibility is assumed by Teledyne Lumenera for its use. Teledyne Lumenera reserves the right to make changes to this information without notice. Reproduction of this manual in whole or in part, by any means, is prohibited without prior permission having been obtained from Teledyne Lumenera. Microsoft and Windows are registered trademarks of Microsoft Corporation in the United States and other countries. Windows, Windows 10 are trademarks of Microsoft Corporation.

All other trademarks or intellectual property mentioned herein belong to their respective owners.

Document Date: June 16, 2021

Document Number: LT-UBLM-USR00

About Teledyne Lumenera — a business unit of Teledyne Digital Imaging Inc.

Teledyne Lumenera, a business unit of Teledyne Digital Imaging Inc., is headquartered in Ottawa, Canada, and is a leading developer and manufacturer of high-performance digital cameras and custom imaging solutions. Teledyne Lumenera imaging solutions provide a unique combination of speed, resolution and sensitivity to meet the most demanding digital imaging requirements, and are deployed worldwide in a wide range of industrial and scientific applications.

Teledyne Imaging is an international high performance semiconductor and Electronics Company that designs, develops, manufactures, and markets digital imaging products and solutions, in addition to providing wafer foundry services.

Teledyne Digital Imaging offers the widest range of machine vision components in the world. From industry-leading image sensors through powerful and sophisticated cameras, frame grabbers, vision processors and software to easy-to-use vision appliances and custom vision modules.

This document does not contain information whose export/transfer/disclosure is restricted by the Canadian Export Control regulation.

Contents

- 1 BOARD-LEVEL OVERVIEW 1**
- 1.1 DESCRIPTION 1
- 1.2 MODEL PART NUMBERS 2
 - 1.2.1 Monochrome Cameras 2
 - 1.2.2 Color Cameras 3
 - 1.2.3 Optional Accessories 4
- 1.3 SOFTWARE REQUIREMENTS 5
 - 1.3.1 Firmware Files for all Lt Models 5
 - 1.3.1.1 Sopera LT 5
 - 1.3.1.2 Lumenera API 5
 - 1.3.1.3 Switching Camera Modes 5
- 2 SERIES SPECIFICATIONS 6**
- 2.1 COMMON SPECIFICATIONS 6
 - 2.1.1 Sensor Cosmetic Specifications 7
 - 2.1.2 Dynamic Range & Signal to Noise Ratio Measurement Conditions 7
 - 2.1.3 Mean Time between Failure (MTBF) 8
- 3 SONY SENSOR MODELS 9**
- 3.1 SPECIFICATIONS: LT-M1610 / LT-C1610 9
 - 3.1.1 Quantum Efficiency Curves (IMX432) 10
- 3.2 SPECIFICATIONS: LT-M1630 / LT-C1630 11
 - 3.2.1 Quantum Efficiency Curves (IMX430) 12
- 3.3 SPECIFICATIONS: LT-C1900 13
 - 3.3.1 Quantum Efficiency Curves (IMX327) 14
- 3.4 SPECIFICATIONS: LT-M1950 / LT-C1950 15
 - 3.4.1 Quantum Efficiency Curves (IMX392) 16
- 3.5 SPECIFICATIONS: LT-M1980 / LT-C1980 17
 - 3.5.1 Quantum Efficiency Curves (IMX429) 18
- 3.6 SPECIFICATIONS: LT-M2020 / LT-C2020 19
 - 3.6.1 Quantum Efficiency Curves (IMX265) 20
- 3.7 SPECIFICATIONS: LT-M2420 / LT-C2420 21
 - 3.7.1 Quantum Efficiency Curves (IMX264) 22
- 3.8 SPECIFICATIONS: LT-M3200 / LT-C3200 23
 - 3.8.1 Quantum Efficiency Curves (IMX428) 24
- 3.9 SPECIFICATIONS: LT-M3840 / LT-C3840 25
 - 3.9.1 Quantum Efficiency Curves (IMX334) 26
- 3.10 SPECIFICATIONS: LT-M4030 / LT-C4030 27
 - 3.10.1 Quantum Efficiency Curves (IMX267) 28
- 3.11 SPECIFICATIONS: LT-M4020 / LT-C4020 29
 - 3.11.1 Quantum Efficiency Curves (IMX304) 30
- 3.12 SPECIFICATIONS: LT-M5500 / LT-C5500 31
 - 3.12.1 Quantum Efficiency Curves (IMX183) 32
- 3.13 GUIDE TO USING A ROLLING SHUTTER CAMERA 33
 - 3.13.1 Overview of Electronic Rolling Shutter (ERS) Exposures 34
 - 3.13.2 Overview of Global Reset Release (GRR) Exposures 35

4	CONNECTING THE CAMERA	36
4.1	USB VISION OVERVIEW	36
4.2	CONNECTING POWER	36
4.2.1	Connectors	36
4.2.2	LED Status Indicator	37
4.3	PREVENTING OPERATIONAL FAULTS DUE TO ESD	37
5	FEATURE REFERENCE	39
5.1	LT SERIES FEATURES	39
5.2	CAMERA INFORMATION CATEGORY	39
5.2.1	Camera Information Feature Descriptions	40
5.3	SENSOR CONTROL CATEGORY	41
5.3.1	Sensor Control Feature Descriptions	41
5.3.2	High gain conversion mode	43
5.4	I/O CONTROL CATEGORY	44
5.4.1	I/O Control Feature Descriptions	44
5.4.1.1	Input and Output Line Details	48
5.4.1.2	Strobe and Flash Zone (Lt-3840, Lt-5500)	48
5.5	ADVANCED PROCESSING CONTROL CATEGORY	49
5.5.1	Advanced Processing Control Feature Descriptions	50
5.6	IMAGE FORMAT CONTROL CATEGORY	51
5.6.1	Image Format Control Feature Description	51
5.6.2	Width and Height Features for Partial Scan Control	53
5.6.2.1	Vertical Cropping (Partial Scan)	53
5.6.2.2	Horizontal Cropping (Partial Scan)	54
5.6.3	Horizontal and Vertical Flip	54
5.7	ACQUISITION CONTROL CATEGORY	56
5.7.1	Acquisition Control Feature Descriptions	56
5.8	EVENT CONTROL CATEGORY	58
5.8.1	Event Control Feature Descriptions	59
5.9	TRANSPORT LAYER CONTROL CATEGORY	60
5.9.1	Transport Layer Feature Descriptions	60
5.10	TELEDYNE LUMENERA CONTROL CATEGORY	61
5.10.1	Teledyne Lumenera Control Feature Descriptions	61
5.11	FILE ACCESS CONTROL CATEGORY	62
5.11.1	File Access Control Feature Descriptions	62
5.11.2	File Access via the CamExpert Tool (Quick Camera Firmware Upgrade)	64
5.12	USB3 VISION HOST CONTROLS CATEGORY	65
6	TECHNICAL SPECIFICATIONS	66
6.1	IDENTIFICATION AND MECHANICAL NOTES	66
6.2	MECHANICAL SPECIFICATIONS	67
6.3	TEMPERATURE MANAGEMENT	68
6.4	SENSOR ALIGNMENT SPECIFICATION	68
6.5	CONNECTORS	69
6.5.1	Connector Locations for Series LT-xx1x-xxxx	69
6.5.1.1	I/O Connector Pinout Details	69
6.5.2	Bi-directional I/O DC Specifications	70
6.5.3	Optically-Isolated Input Specifications	70
6.5.4	Optically-Isolated Output Specifications	70
6.6	COMPUTER REQUIREMENTS FOR LT CAMERAS	71
6.7	EC & FCC DECLARATIONS OF CONFORMITY	72

7	ADDITIONAL REFERENCE INFORMATION	73
7.1	CHOOSING A LENS WITH THE CORRECT IMAGE CIRCLE	73
7.1.1	<i>Lens Options for Lt-1900</i>	73
7.1.2	<i>Lens Options for Lt-1950</i>	74
7.1.3	<i>Lens Options for Lt-2020, Lt-3840</i>	74
7.1.4	<i>Lens Options for Lt-1980, Lt-2420</i>	75
7.1.5	<i>Lens Options for Lt-1630</i>	75
7.1.6	<i>Lens Options for Lt-4030, Lt-5500</i>	76
7.1.7	<i>Lens Options for Lt-1610, Lt-3200, Lt-4020</i>	76
7.1.8	<i>Additional Lens Parameters (application specific)</i>	77
7.2	OPTICAL CONSIDERATIONS	77
7.2.1	<i>Illumination</i>	77
7.2.2	<i>Light Sources</i>	78
7.3	SENSOR HANDLING INSTRUCTIONS	78
7.3.1	<i>Electrostatic Discharge and the Sensor</i>	78
7.3.2	<i>Protecting Against Dust, Oil and Scratches</i>	78
7.3.3	<i>Cleaning the Sensor Window</i>	79
7.4	RUGGEDIZED CABLE ACCESSORIES	79
7.4.1	<i>Cable Manufacturers Contact Information</i>	79
7.4.2	<i>Long Passive Cables and Optical Cables</i>	80
7.4.3	<i>USB3 Long Distance Active Cables</i>	80
8	TROUBLESHOOTING	81
8.1	OVERVIEW	81
8.2	USB3 CAMERA FAQ ITEMS	81
8.3	USING THE U3V DEVICE MANAGER TOOL	82
8.4	SWITCHING A LUMENERA CAMERA FROM LUCAM MODE TO USB3 VISION MODE	82
8.5	SWITCHING A LUMENERA CAMERA FROM USB3 VISION MODE TO LUCAM MODE	83
8.6	TROUBLESHOOTING FLOW CHARTS	83
8.6.1	<i>Chart 1</i>	84
8.6.2	<i>Chart 2</i>	85
8.6.3	<i>Chart 3</i>	86
8.6.4	<i>Chart 4</i>	87
9	REVISION HISTORY	88
10	CONTACT INFORMATION	89
10.1	SALES INFORMATION	89
10.2	TECHNICAL SUPPORT	89

1 Board-Level Overview

1.1 Description

Teledyne Lumenera USB 3 Vision compliant cameras provide a quick and easy means of capturing high quality images on any USB 3.0 equipped desktop, laptop or embedded computer. Because they are USB-based, there is no need for a frame grabber. Instead, a single cable provides full command control and data transfer at speeds of up to 380 MB/s (LT series).

USB 3 cameras are powered via the USB 3 computer port. Cameras also have an external interface header for hardware input, output signals and optional camera power.

Some of the Lt Board-Level Series feature highlights include:

- Compliant with third party USB3 Vision application development software
- Color or monochrome Sony IMX series CMOS sensors (global shutter & rolling shutter)
- High-Speed USB 3.1 Gen 1 interface for fastest image delivery and simplified connectivity
- 128 MB low-latency RAM frame buffer
- Transfer Burst Mode supported
- Region of Interest (ROI) option to provide higher frame rates
- Selectable 8- or 12-bit pixel data
- Multiple data rates supported, each optimized for lowest noise performance
- Compact, robust form factor
- Locking industrial micro USB (power / data) and General Purpose I/O connectors for control of peripherals and lighting synchronization
- The **LT-xx1x-xxxxNBL** series has a reduced I/O signal set on a locking 9-pin connector

1.2 Model Part Numbers

This manual covers the monochrome and color models summarized in the tables below. Specific camera model specifications follow this section.

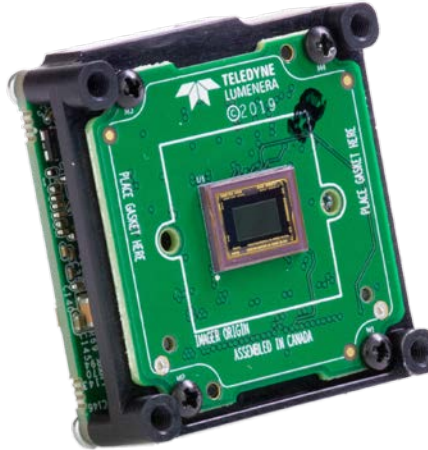

Models P/N: LT- xx1x-xxxxNBL

1.2.1 Monochrome Cameras

All models use Global Shutter sensors unless designated with ***RS** for Rolling Shutter.

Lt Model Full Resolution	Sensor & Size	Lens Mount case version	Lens Image Circle	Lt Part Number
<u>Lt-M1610B</u> 1608 X 1104	Sony 1.7M (IMX432)	No mount No casing	1.1"	LT-UM11-M161NBL
<u>Lt-M1630B</u> 1632 x 1248	Sony 2.0M (IMX430)	No mount No casing	1/1.7"	LT-UM11-M163NBL
<u>Lt-M1950B</u> 1936 x 1216	Sony 2.3M (IMX392)	No mount No casing	1/2.3"	LT-UM10-M195NBL
<u>Lt-M1980B</u> 1944 x 1492	Sony 2.9M (IMX429)	No mount No casing	2/3"	LT-UM11-M198NBL
<u>Lt-M2020B</u> 2064 x 1544	Sony 3.2M (IMX265)	No mount No casing	1/1.8"	LT-UM11-M202NBL
<u>Lt-M2420B</u> 2464 x 2056	Sony 5.1M (IMX264)	No mount No casing	2/3"	LT-UM11-M242NBL
<u>Lt-M3200B</u> 3216 x 2208	Sony 7.1M (IMX428)	No mount No casing	1.1"	LT-UM11-M320NBL
<u>Lt-M3840B</u> 3840 x 2160	Sony 8.3M (IMX334) *RS	No mount No casing	1/1.8"	LT-UM10-M384NBL



Lt Model Full Resolution	Sensor & Size	Lens Mount case version	Lens Image Circle	Lt Part Number
<u>Lt-M4030B</u> 4112 x 2176	Sony 8.9M (IMX267)	No mount No casing	1"	LT-UM11-M403NBL
<u>Lt-M4020B</u> 4112 x 3008	Sony 12.3M (IMX304)	No mount No casing	1.1"	LT-UM11-M402NBL
<u>Lt-M5500B</u> 5472 x 3648	Sony 20M (IMX183) *RS	No mount No casing	1"	LT-UM10-M550NBL

1.2.2 Color Cameras

All models use Global Shutter sensors unless designated with *RS for Rolling Shutter.



Lt Model Full Resolution	Sensor & Size	Lens Mount case version	Lens Image Circle	Part Number
<u>Lt-C1610B</u> 1608 X 1104	Sony 1.7M (IMX432)	No mount No casing	1.1"	LT-UC11-C161NBL
<u>Lt-C1630B</u> 1632 x 1248	Sony 2.0M (IMX430)	No mount No casing	1/1.7"	LT-UC11-C163NBL
<u>Lt-C1900B</u> 1944 x 1096	Sony 2.1M (IMX327) *RS	No mount No casing	1/2.8"	LT-UC10-C190NBL
<u>Lt-C1950B</u> 1936 x 1216	Sony 2.3M (IMX392)	No mount No casing	1/2.3"	LT-UC10-C195NBL
<u>Lt-C1980B</u> 1944 x 1492	Sony 2.9M (IMX429)	No mount No casing	2/3"	LT-UC11-C198NBL
<u>Lt-C2020B</u> 2064 x 1544	Sony 3.2M (IMX265)	No mount No casing	1/1.8"	LT-UC11-C202NBL
<u>Lt-C2420B</u> 2464 x 2056	Sony 5.1M (IMX264)	No mount No casing	2/3"	LT-UC11-C242NBL
<u>Lt-C3200B</u> 3216 x 2208	Sony 7.1M (IMX428)	No mount No casing	1.1"	LT-UC11-C320NBL
<u>Lt-C3840B</u> 3840 x 2160	Sony 8.3M (IMX334) *RS	No mount No casing	1/1.8"	LT-UC10-C384NBL
<u>Lt-C4030B</u> 4112 x 2176	Sony 8.9M (IMX267)	No mount No casing	1"	LT-UC11-C403NBL
<u>Lt-C4020B</u> 4112 x 3008	Sony 12.3M (IMX304)	No mount No casing	1.1"	LT-UC11-C402NBL
<u>Lt-C5500B</u> 5472 x 3648	Sony 20M (IMX183) *RS	No mount No casing	1"	LT-UC10-C550NBL

1.2.3 Optional Accessories

Accessories & Cables for camera series LT-xx1x-xxxxNBL	Part Number	
USB 3.1 Cable A-Male to Micro-B male Locking (3m / 9.75ft)	La303ML	
GPIO Sync cable, 9-Pin with I/O lead (power & lead cable)	La4000PAFL	

See section **Ruggedized Cable Accessories** cabling options available directly from our preferred cable sources.

1.3 Software Requirements

	Windows OS & USB3 Vision Series Lt-Uxxx-xxxx models are compatible with the Teledyne Spera LT software SDK (USB3 Vision compliant) or a third-party USB3 Vision compliant SDK.
	Windows OS & Lumenera LuCam API Series Lt-Lxxx-xxxx models are available for the Lumenera LuCam software API. This series is not USB3 Vision compliant.
	Linux OS & Lumenera LuCam API Series Lt-Lxxx-xxxx models are available for the Linux software API. USB3 Vision and LuCam can be used with the Linux API.

1.3.1 Firmware Files for all Lt Models

The latest firmware files for all Lt Models are available on the Teledyne Lumenera Lt Series support web site (subject to change):

<https://www.lumenera.com/support/industrial-usb-ethernet/drivers-downloads/usb3-camera-firmware-updater.html>

Firmware files are in the standard Spera .cbf format.

1.3.1.1 Spera LT

When using Spera LT, update the camera firmware using CamExpert (see **File Access via the CamExpert Tool (Quick Camera Firmware Upgrade)**). The Camera firmware can easily be upgraded within your own application via the API. The camera has a failsafe scheme which prevents unrecoverable camera errors even in the case of a power interruption.

1.3.1.2 Lumenera API

When using Lumenera API, use the Lumenera Updater tool.

1.3.1.3 Switching Camera Modes

The camera can be switched between LuCam mode and USB3 Vision mode as required by the user. See **Switching a Lumenera camera from LuCam mode to USB3 Vision mode** and **Switching a Lumenera camera from USB3 Vision mode to LuCam mode** for details on the procedure.

2 Series Specifications

The common specifications listed first are followed by model specific tables of functional features and timing details.

2.1 Common Specifications

Camera Controls	
Synchronization Modes	Free running, External triggered, Software Triggered
Exposure Control	Internal – Programmable via the camera API External – based on Trigger Width
Exposure Mode	Programmable with time increments which are camera model specific Minimum (in μs) is model specific Pulse controlled via Trigger pulse width
Inputs/Outputs	2 GPI/O bi-directional terminals 1 optically isolated input 1 optically isolated output 3.3 Vdc output source (maximum 150 mA)
Features	
Flash memory	Non-volatile flash memory implemented
Image Buffer	128MB
Gain	Manual and automatic control – Analog and Digital (sensor specific)
Auto-Exposure	Yes with user set target luminance level
Color model output	Color cameras support BayerBG8 and BayerBG16 output modes.
LUT	Programmable LUT (Look-up-table)
Timestamp	Timer to Timestamp images and events
Mechanical Interface	
Data Interface	USB 3.1, micro-b locking connector
I/O Interface	Locking 9-pin JST NSHR-09V-S
Camera Dimensions	40 x 40 x 14 to 17 mm
Mass	~ 28 g (approximate value)
Electrical Interface	
Input Voltage	Supports power over USB3 Alternatively via the auxiliary I/O connector: 5 Vdc, 1.5 A
Power Dissipation (typical)	2.3 W to 3.6 W
Environmental Conditions	
Operating Temperature (at camera front plate)	All Models: 0°C to +50°C <i>Any metallic camera mounting provides heat-sinking which consequently reduces the internal temperature.</i>
Operating Relative Humidity	5% to 95% non-condensing
Storage	-30°C to +70°C
Conformity	FCC Class B & CE Certified, RoHS & WEEE Compliant
Shock / Vibration	EC60721-4-7 Class 7M2 & IEC60068-2-27
Sinusoidal & Random Vibration	IEC60721-4-7 Class 7M2 & IEC60721-4-2 Class 2M2 IEC60068-2-6 & IEC60068-2-64

2.1.1 Sensor Cosmetic Specifications

After Factory Calibration and/or Corrections are applied (dependent on sensor)

Blemish Specifications	Maximum Number of Defects	Blemish Description
Hot/Dead Pixel defects	Typical 0.0025% Max 0.005%	Any pixel that deviates by $\pm 20\%$ from the average of neighboring pixels at 50% saturation including pixel stuck at 0 and maximum saturated value.
Spot defects	None	Grouping of more than 8 pixel defects within a sub-area of 3x3 pixels, to a maximum spot size of 7x7 pixels.
Clusters defects	None	Grouping of more than 5 single pixel defects in a 3x3 kernel.
Column defects	None	Vertical grouping of more than 10 contiguous pixel defects along a single column.
Row defects	None	Horizontal grouping of more than 10 contiguous pixel defects along a single row.

Cleanliness Test conditions

- Nominal light = illumination at 60% of saturation
- Camera temperature $\leq 55^{\circ}\text{C}$
- At exposures lower than 0.1 seconds
- At gain = 1(Lt-2020B), 3(Lt-2420B), 3(Lt-4030B), 3(Lt-4020B)

Defective Pixel Correction Test conditions

- Gray: illumination at 60% of saturation, gain = 1(Lt-2020B), 3(Lt-2420B), 3(Lt-4030B), 3(Lt-4020B)
- Black: gain = 15
- Camera temperature = $50^{\circ}\text{C} - 55^{\circ}\text{C}$

Sony Sensor Limitation

- Max pixel saturated values: Max Pixel format bit depth – 4095 (12-bit)

2.1.2 Dynamic Range & Signal to Noise Ratio Measurement Conditions

Specifications calculated according to EMVA-1288 standard, using white LED light

Dynamic Range Test Conditions

- Exposure 100 μs for 0% Full Light Level
- Lt-x1610B exposure 6 ms, gain 1, variable light source from dark to saturation
- Lt-x1630B exposure 40 ms, gain 1, variable light source from dark to saturation
- Lt-x1900B exposure 17 ms, gain 1, variable light source from dark to saturation
- Lt-x1950B exposure 60 ms, gain 1, variable light source from dark to saturation
- Lt-x1980B exposure 75 ms, gain 1, variable light source from dark to saturation
- Lt-x2020B exposure 16 ms, gain 1, variable light source from dark to saturation
- Lt-x2420B exposure 28 ms, gain 1, variable light source from dark to saturation
- Lt-x3200B exposure 38 ms, gain 1, variable light source from dark to saturation
- Lt-x3840B exposure 43 ms, gain 1, variable light source from dark to saturation
- Lt-x4030B exposure 150 ms, gain 1, variable light source from dark to saturation
- Lt-x4020B exposure 150 ms, gain 1, variable light source from dark to saturation
- Lt-x5500B exposure 10 ms gain 1, variable light source from dark to saturation

SNR Test Conditions

- Exposure 2000 μ s
- 80% saturation

2.1.3 Mean Time between Failure (MTBF)

Teledyne Lumenera MTBF calculations use the Parts Count/Parts Stress method. Calculated assembly FIT values are rounded up with margin to provide adequate headroom and the final quoted MTBF is then rounded down to the nearest year.

In practice, MILSTD217F is used to model passive and simple active parts, such as diodes and transistors, because manufacturer data is unreliable. When MILSTD217F models are used to represent more than one physical part, worst case parameters are used. Manufacturer's data is used to model more complicated active parts, such as buffers and FPGAs, because the internal structures are not known and the manufacturer data is more likely to be valid. When manufacturer data is used, it is modified to meet specific use conditions using the Arrhenius equation and the result is set to a 90% confidence level using the Chi-Squared Distribution Method. Again, when more than one of the same part exists on an assembly, worst case parameters are used. Manufacturer data is either obtained from the manufacturer's website or provided directly from the manufacturer.

The calculated MTBF only considers electronic components. It does not include mechanical parts unless specified.

MTBF assumptions

- Fixed Ground Environment Readily Accessible for Maintenance
- Manufactured to Specification
- Proper Operating Conditions/Environment During Life Cycle

It is important to note that the MTBF result provided here is subject to change due to design changes or as new reliability/test data becomes available.

Calculation Results

Lt Series Product MTBF Results	
FIT Value	9500
MTBF Years	12.02

3 Sony Sensor Models

Cameras utilizing Sony sensors (monochrome and color) are described.

3.1 Specifications: Lt-M1610 / Lt-C1610

Supported Features	Lt-M1610 / Lt-C1610	
Resolution	1608 x 1104	
Sensor	Sony IMX432 (1.7 MP)	
Pixel Size	9.00 μm x 9.00 μm	
Optical Format	1.1"	
Shutter type	Full frame electronic global shutter function	
Full Well charge	100.4 ke (max)	
Pixel Data Formats	Monochrome 8-bit or 12-bit	Bayer 8-bit or 12-bit
Max. Internal Frame Rate Full resolution	96.3 fps (8-bit, 12-bit)	
Maximum Sustained Frame Rate Output	96.3 fps (8-bit)	
Exposure Time Range	5 μs – 4295 s (triggered) 14 μs – 9.2 s (continuous)	
Trigger to Exposure Minimum Delay	1 μs	
Actual Exposure Time Minimum	5.00 μs (triggered) 13.81 μs (continuous) (Exposure time increment steps = Horizontal Time Line)	
Min. Time from End of Exposure to Start of Next Exposure	105.7 μs	
Horizontal Line Time	8.81 μs	
Readout Time	10.36 ms (Horizontal Line Time) x (lines in frame + 72) — in μs	
Auto-Exposure	Yes, with Auto-Brightness Target	
Black offset control	Yes (in DN)	
Gain Control	Yes (256 max)	
Color Enhancement Support	Monochrome Model — No	Color Model — Yes (Brightness, Contrast, Gamma)
Defective Pixel Replacement	Yes	
Image Correction	No	
Image Flip Support	Yes – On Sensor, Vertical and Horizontal	
Binning Support	Yes, monochrome model	
Multi-ROI Support	No	
Decimation Support	Yes – $\frac{1}{2}\times$, vertical and horizontal	
On-Board Image Memory	Yes (128 MB)	
Output Dynamic Range (dB)	72.7 dB	
SNR	50.0 dB	

3.1.1 Quantum Efficiency Curves (IMX432)

The response curves describe the sensor, excluding lens and light source characteristics.

Models – Monochrome

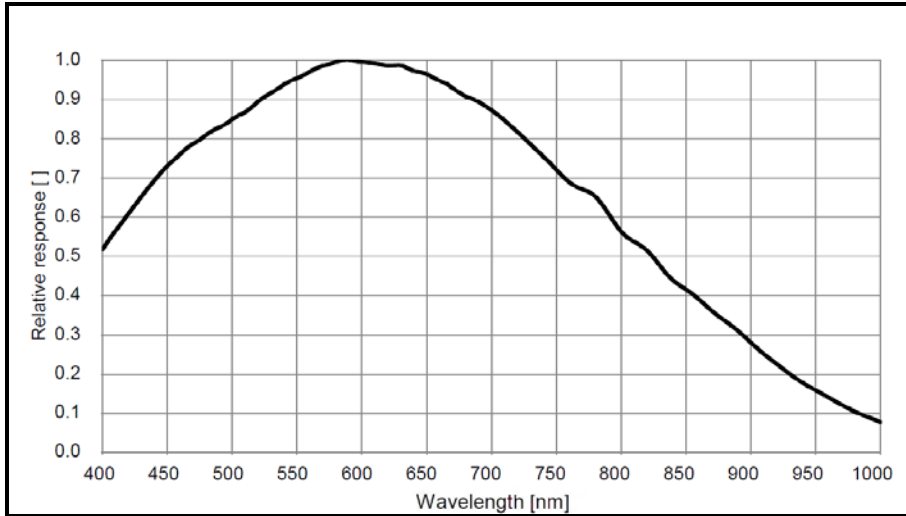

Models – Color

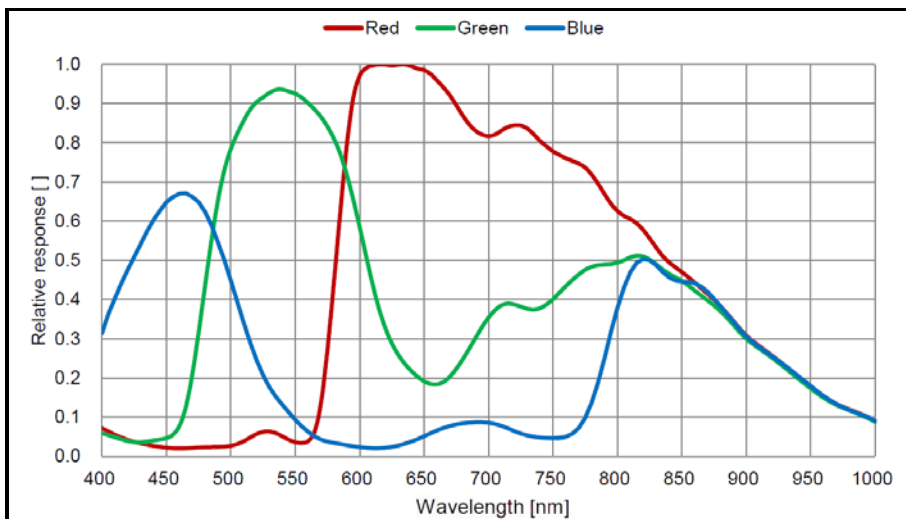

3.2 Specifications: Lt-M1630 / Lt-C1630

Supported Features	Lt-M1630 / Lt-C1630	
Resolution	1632 x 1248	
Sensor	Sony IMX430 (2.0 MP)	
Pixel Size	4.50 μm x 4.50 μm	
Optical Format	1/1.7"	
Shutter type	Full frame electronic global shutter function	
Full Well charge	25.1 ke (max)	
Pixel Data Formats	Monochrome 8-bit or 12-bit	Bayer 8-bit or 12-bit
Max. Internal Frame Rate Full resolution	85.7 fps (8-bit, 12-bit)	
Maximum Sustained Frame Rate Output	85.7 fps (8-bit)	
Exposure Time Range	5 μs – 4295 s (triggered) 14 μs – 151.8 s (continuous)	
Trigger to Exposure Minimum Delay	1 μs	
Actual Exposure Time Minimum	5.00 μs (triggered) 14.05 μs (continuous) (Exposure time increment steps = Horizontal Time Line)	
Min. Time from End of Exposure to Start of Next Exposure	54.3 μs	
Horizontal Line Time	9.05 μs	
Readout Time	11.64 ms (Horizontal Line Time) x (lines in frame + 38) — in μs	
Auto-Exposure	Yes, with Auto-Brightness Target	
Black offset control	Yes (in DN)	
Gain Control	Yes (256 max)	
Color Enhancement Support	Monochrome Model – No	Color Model – Yes (Brightness, Contrast, Gamma)
Defective Pixel Replacement	Yes	
Image Correction	No	
Image Flip Support	Yes – On Sensor, Vertical and Horizontal	
Binning Support	Yes, monochrome model	
Multi-ROI Support	No	
Decimation Support	Yes, 1/2x Vertical and Horizontal	
On-Board Image Memory	Yes (128 MB)	
Output Dynamic Range (dB)	72.7 dB	
SNR	44.0 dB	

3.2.1 Quantum Efficiency Curves (IMX430)

The response curves describe the sensor, excluding lens and light source characteristics.

Models – Monochrome

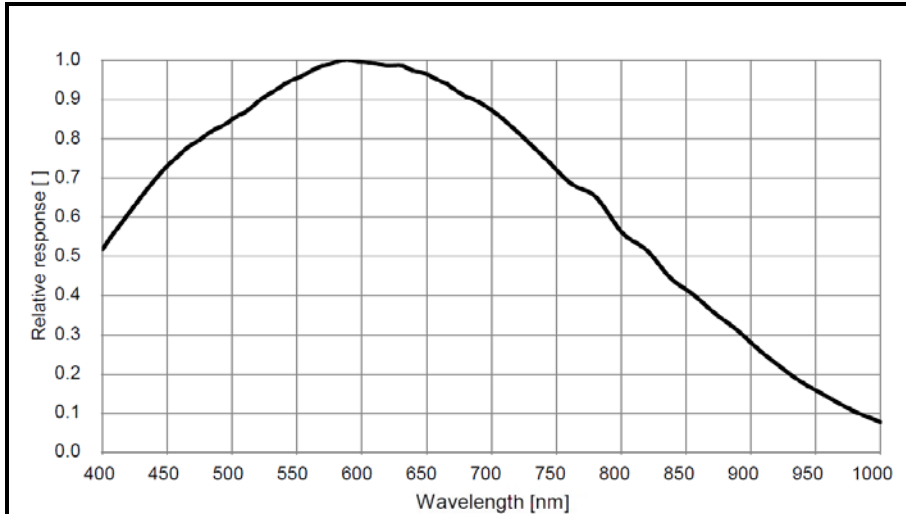

Models – Color

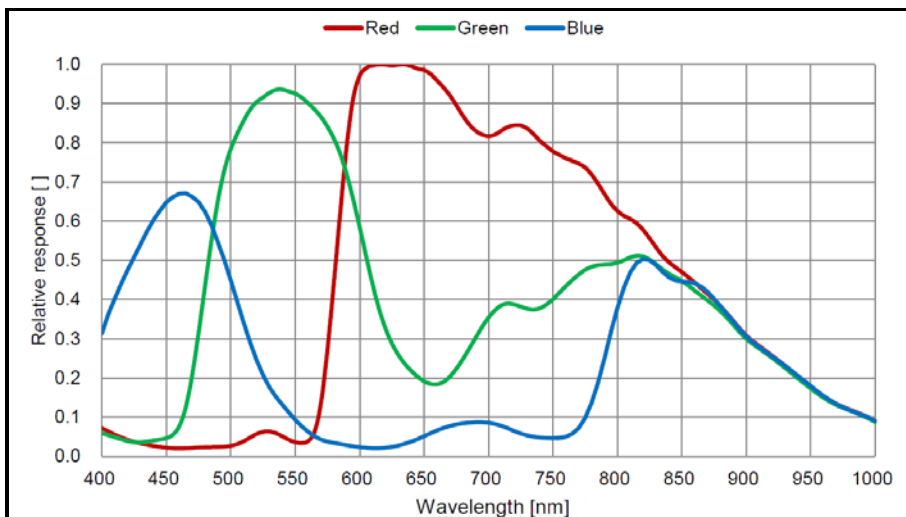

3.3 Specifications: Lt-C1900

Model specific specifications and response graphics for the IMX327 sensor are provided here. The response curves exclude lens and light source characteristics.

Supported Features	C1900
Resolution	1944 x 1096
Sensor	Sony IMX327 (2.1 MP)
Pixel Size	2.9 μm x 2.9 μm
Optical Format	1/2.8"
Shutter Type (see Sensor Control Feature Descriptions)	Electronic Rolling Shutter function (ERS) with Global Reset Release (GRR) function
Full Well charge	11.2 ke (max)
Pixel Data Formats	Bayer 8-Bit or 12-Bit
Max. Internal Frame Rate Full resolution	60 fps (8-bit, 12-bit)
Maximum Sustained Frame Rate Output	60 fps (8-bit)
Exposure Time Range	149 μs – 1 s (triggered) 15 μs – 1 s (continuous)
Trigger to Exposure Minimum Delay	1 μs
Actual Exposure Time Minimum	148.15 μs (triggered) 14.81 μs (continuous) (Exposure time increment steps = Horizontal Time Line)
Minimum Time from End of Exposure to Start of Next Exposure	118.5 μs
Horizontal Line Time	29.63 μs (triggered) 14.81 μs (continuous)
Readout Time	32.47 ms (triggered) 16.23 ms (continuous) (Horizontal Line Time) x (Lines in frame) — in μs
Auto-Exposure	Yes, with Auto-Brightness Target (continuous only)
Black Offset control	Yes (in DN)
Gain Control	In-sensor gain (3715x digital max)
Color Enhancement Support	Yes – (Brightness, Contrast, Gamma)
Defective Pixel Replacement	Yes
Image Correction	No
Image Flip Support	Yes, in-sensor, both vertical and horizontal
Binning Support	No
Multi-ROI Support	No
Decimation Support	No
On-board image memory	Yes (128 MB)
Output Dynamic Range	72.7 dB
SNR	40.5 dB

3.3.1 Quantum Efficiency Curves (IMX327)

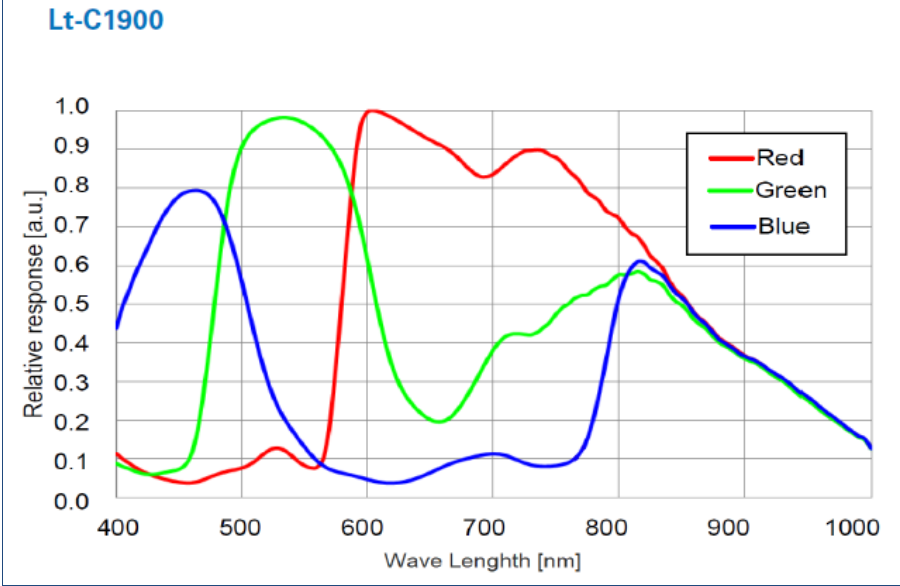

3.4 Specifications: Lt-M1950 / Lt-C1950

Supported Features	Lt-M1950 / Lt-C1950	
Resolution	1932 x 1216	
Sensor	Sony IMX392 (2.3 MP)	
Pixel Size	3.45 μm x 3.45 μm	
Optical Format	1/2.3"	
Shutter type	Full frame electronic global shutter function	
Full Well charge	10.5 ke (max)	
Pixel Data Formats	Monochrome 8-bit or 12-bit	Bayer 8-bit or 12-bit
Max. Internal Frame Rate Full resolution	162 fps (8-bit) / 81 fps (12-bit)	
Maximum Sustained Frame Rate Output	162 fps (8-bit)	
Exposure Time Range	14 μs – 4295 s (triggered) 25 μs – 11.1 s (continuous)	
Trigger to Exposure Minimum Delay	1 μs	
Actual Exposure Time Minimum	13.73 μs (Exposure time increment steps = Horizontal Time Line)	
Min. Time from End of Exposure to Start of Next Exposure	31.7 μs	
Horizontal Line Time	3.96 μs	
Readout Time	4.82 ms (triggered) 4.91 ms (continuous) (Horizontal Line Time) x (lines in frame + 23) — in μs	
Auto-Exposure	Yes, with Auto-Brightness Target	
Black offset control	Yes (in DN)	
Gain Control	Yes (1.0x to 256x)	
Color Enhancement Support	No – Monochrome Models	Yes – Color Models (Brightness, Contrast, Gamma)
Defective Pixel Replacement	Yes	
Image Correction	No	
Image Flip Support	Yes, In-Sensor, Vertical and Horizontal	
Binning Support	Yes, monochrome model	
Multi-ROI Support	No	
Decimation Support	Yes, 1/2x vertical and horizontal	
On-Board Image Memory	Yes – 128 MB	
Output Dynamic Range (dB)	73.4 dB	
SNR	40.2 dB	

3.4.1 Quantum Efficiency Curves (IMX392)

The response curves describe the sensor, excluding lens and light source characteristics.

Models – Monochrome

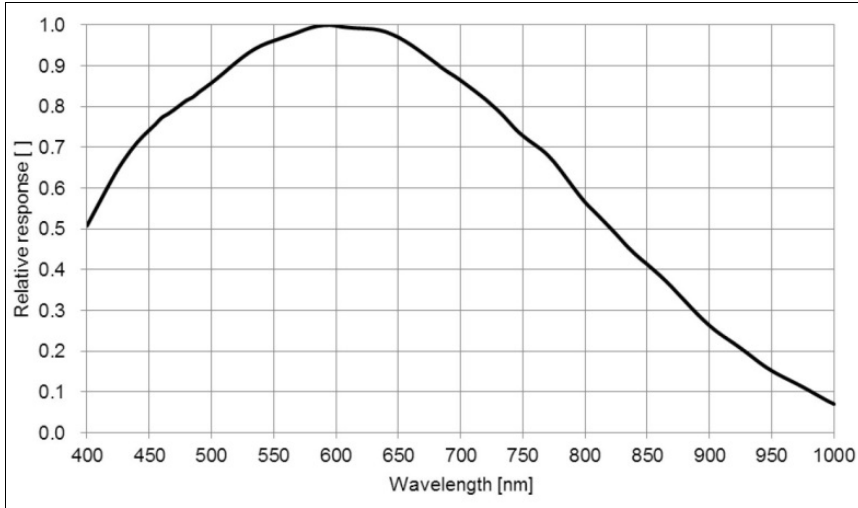

Models – Color

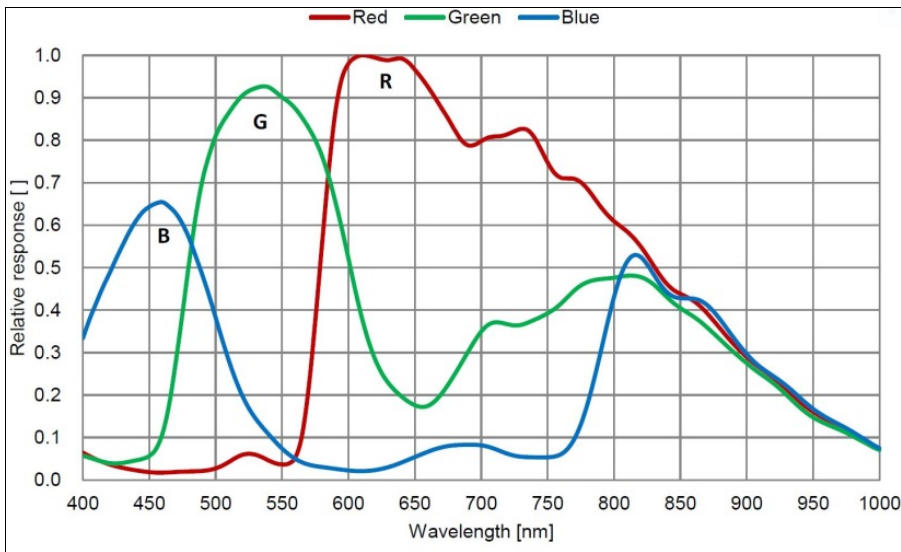

3.5 Specifications: Lt-M1980 / Lt-C1980

Supported Features	Lt-M1980 / Lt-C1980	
Resolution	1944 x 1472	
Sensor	Sony IMX429 (2.9 MP)	
Pixel Size	4.50 μm x 4.50 μm	
Optical Format	2/3"	
Shutter type	Full frame electronic global shutter function	
Full Well charge	24.9 ke	
Pixel Data Formats	Monochrome 8-bit or 12-bit	Bayer 8-bit or 12-bit
Max. Internal Frame Rate Full resolution	62.8 fps (8-bit, 12-bit)	
Maximum Sustained Frame Rate Output	62.8 fps (8-bit)	
Exposure Time Range	5 μs – 4295 s (triggered) 16 μs – 177.1 s (continuous)	
Trigger to Exposure Minimum Delay	1 μs	
Actual Exposure Time Minimum	5.00 μs (triggered) 15.56 μs (continuous) (Exposure time increment steps = Horizontal Time Line)	
Min. Time from End of Exposure to Start of Next Exposure	42.2 μs	
Horizontal Line Time	10.56 μs	
Readout Time	15.92 ms (Horizontal Line Time) x (lines in frame + 36) — in μs	
Auto-Exposure	Yes, with Auto-Brightness Target	
Black offset control	Yes (in DN)	
Gain Control	Yes (256 max)	
Color Enhancement Support	Monochrome Model — No	Color Model — Yes (Brightness, Contrast, Gamma)
Defective Pixel Replacement	Yes	
Image Correction	No	
Image Flip Support	Yes, on sensor, vertical and horizontal	
Binning Support	Yes, monochrome model	
Multi-ROI Support	No	
Decimation Support	Yes, $\frac{1}{2}x$, vertical and horizontal	
On-Board Image Memory	128 MB	
Output Dynamic Range (dB)	72.0 dB	
SNR	43.9 dB	

3.5.1 Quantum Efficiency Curves (IMX429)

The response curves describe the sensor, excluding lens and light source characteristics.

Models – Monochrome

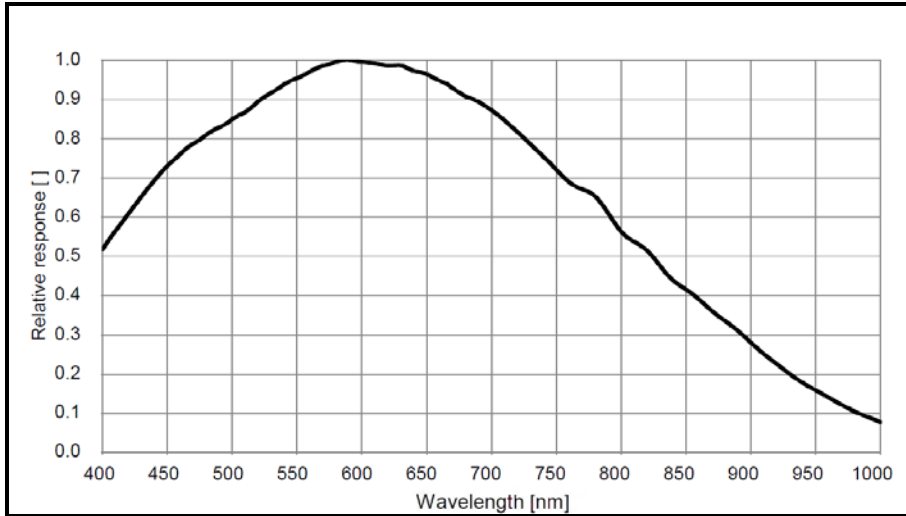

Models – Color

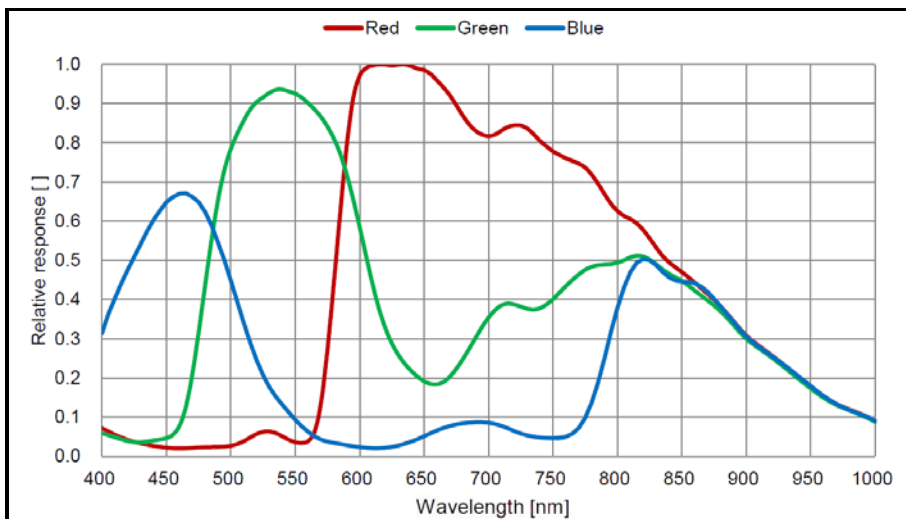

3.6 Specifications: Lt-M2020 / Lt-C2020

Supported Features	M2020	C2020
Resolution	2064 x 1544	
Sensor	Sony IMX265 (3.2 MP)	
Pixel Size	3.45 μm x 3.45 μm	
Optical Format	1/1.8"	
Shutter type	Full frame electronic global shutter function	
Full Well charge	10.9 ke (max)	
Pixel Data Formats	Mono 8-bit & 12-bit	Bayer 8-Bit & 12-Bit
Max. Internal Frame Rate Full resolution	55 fps (8-bit, 12-bit)	
Maximum Sustained Frame Rate Output	55 fps (8-bit)	
Exposure Time Range	14 μs – 4295 s (triggered) 14 μs – 11.9 s (continuous)	
Trigger to Exposure Minimum delay	1 μs (Exposure time increment steps = Horizontal Time Line)	
Actual Exposure Time Minimum	13.73 μs	
Min. Time from End of Exposure to Start of Next Exposure (second frame)	91.2 μs	
Horizontal Line Time	11.40 μs	
Readout Time	17.60 ms (triggered) 17.80 (continuous) (Horizontal Line Time) x (lines in frame + 17) — in μs	
Auto-Exposure	Yes, with Auto-Brightness Target	
Black offset control	Yes (in DN)	
Gain Control	In-sensor Gain (1.0x to 256x)	
Color Enhancement Support	No – Monochrome Models	Yes – Color Models (Brightness, Contrast, Gamma)
Defective Pixel Replacement	Yes	
Image Correction	No	
Image Flip Support	Yes, In-Sensor, Vertical and Horizontal	
Binning Support	No	
Multi-ROI Support	No	
Decimation Support	Yes, 1/2x vertical and horizontal	
On-Board Image Memory	Yes (128MB)	
Output Dynamic Range (dB)	73.8 dB	
SNR	41.1 dB	

3.6.1 Quantum Efficiency Curves (IMX265)

The response curves describe the sensor, excluding lens and light source characteristics.

Models – Monochrome

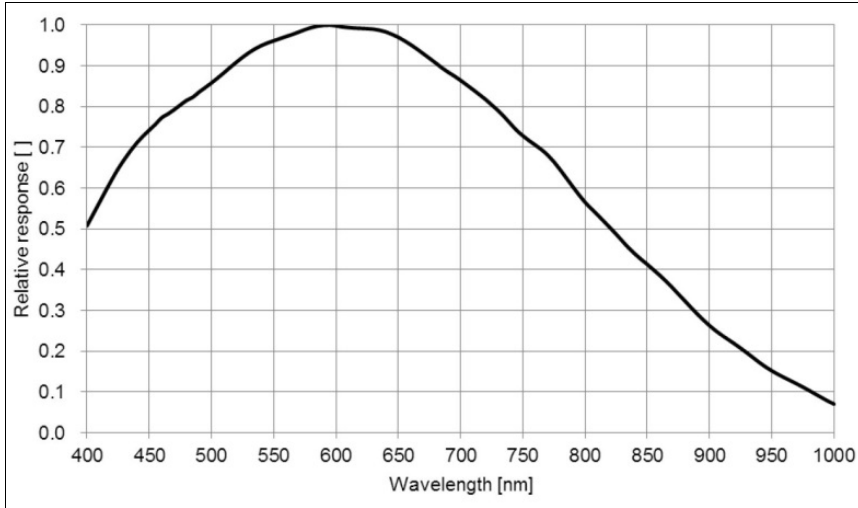

Models – Color

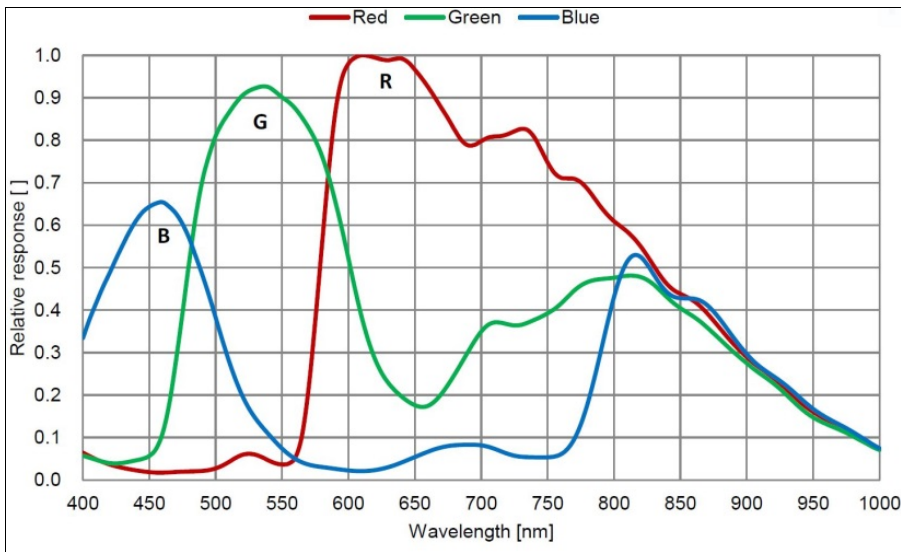

3.7 Specifications: Lt-M2420 / Lt-C2420

Supported Features	Lt-M2420 / Lt-C2420	
Resolution	2464 x 2056	
Sensor	Sony IMX264 (5.1 MP)	
Pixel Size	3.45 μm x 3.45 μm	
Optical Format	2/3"	
Shutter type	Full frame electronic global shutter function	
Full Well charge	10.3 ke (max)	
Pixel Data Formats	Monochrome 8-bit or 12-bit	Bayer 8-bit or 12-bit
Max. Internal Frame Rate Full resolution	35 fps (8 and 12-bit)	
Maximum Sustained Frame Rate Output	35 fps (8-bit)	
Exposure Time Range	14 μs – 4295 s (triggered) 14 μs – 14.1 s (continuous)	
Trigger to Exposure Minimum delay	1 μs	
Actual Exposure Time Minimum	13.73 μs (Exposure time increment steps = Horizontal Time Line)	
Min. Time from End of Exposure to Start of Next Exposure	107.3 μs	
Horizontal Line Time	13.40 μs	
Readout Time	27.55 ms (triggered) 27.78 (continuous) (Horizontal Line Time) x (lines in frame + 17) — in μs	
Auto-Exposure	Yes, with Auto-Brightness Target	
Black offset control	Yes (in DN)	
Gain Control	In-sensor Gain (1.0x to 256x)	
Color Enhancement Support	No – Monochrome Models	Yes – Color Models (Brightness, Contrast, Gamma)
Defective Pixel Replacement	Yes	
Image Correction	No	
Image Flip Support	Yes, in sensor, Vertical and Horizontal	
Binning Support	No	
Multi-ROI Support	No	
Decimation Support	Yes, 1/2x vertical and horizontal	
On-Board Image Memory	128 MB	
Output Dynamic Range (dB)	73.0 dB	
SNR	40.2 dB	

3.7.1 Quantum Efficiency Curves (IMX264)

The response curves describe the sensor, excluding lens and light source characteristics.

Monochrome

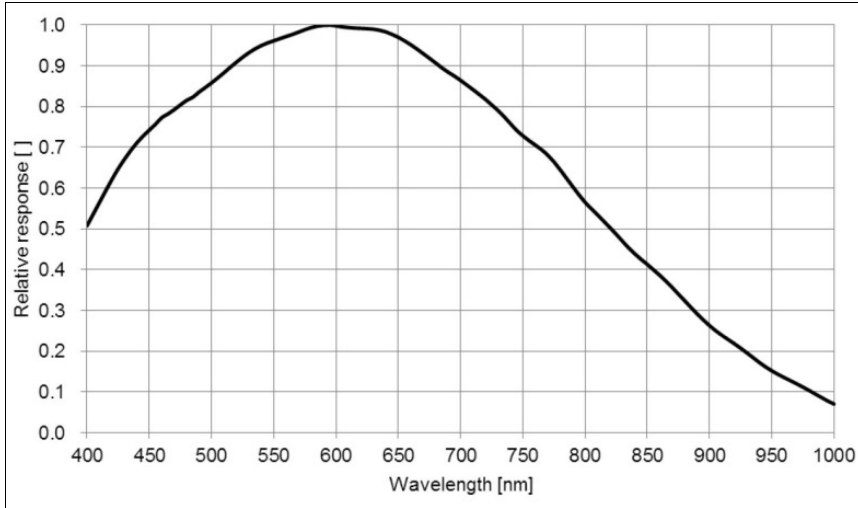

Color

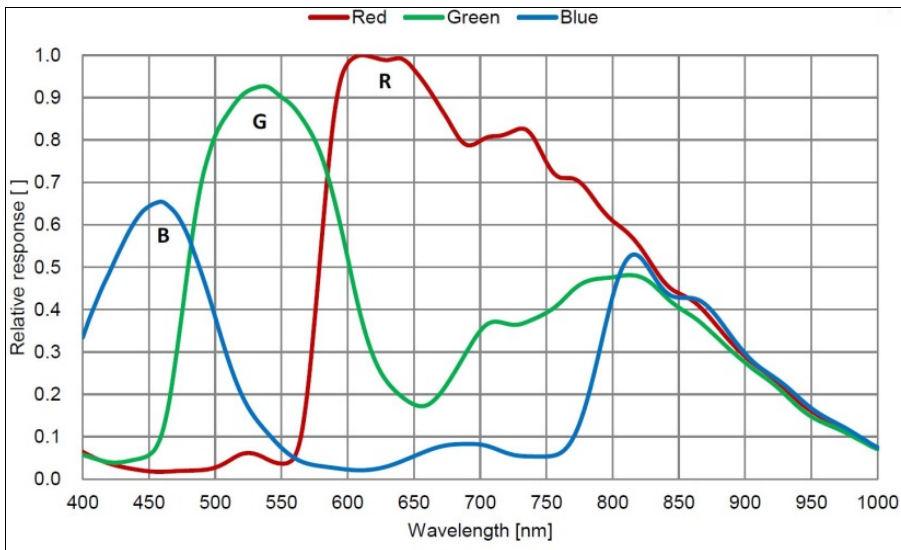

3.8 Specifications: Lt-M3200 / Lt-C3200

Supported Features	Lt-M3200 / Lt-C3200	
Resolution	3216 x 2208	
Sensor	Sony IMX428 (7.1 MP)	
Pixel Size	4.50 μm x 4.50 μm	
Optical Format	1.1"	
Shutter type	Full frame electronic global shutter function	
Full Well charge	25.2 ke (max)	
Pixel Data Formats	Monochrome 8-bit or 12-bit	Bayer 8-bit or 12-bit
Max. Internal Frame Rate Full resolution	50 fps (8-bit, 12-bit)	
Maximum Sustained Frame Rate Output	50 fps (8-bit)	
Exposure Time Range	5 μs – 4295 s (triggered) 14 μs – 9.2 s (continuous)	
Trigger to Exposure Minimum Delay	1 μs	
Actual Exposure Time Minimum	5.00 μs (triggered) 13.81 μs (continuous) (Exposure time increment steps = Horizontal Time Line)	
Min. Time from End of Exposure to Start of Next Exposure	105.7 μs	
Horizontal Line Time	8.81 μs	
Readout Time	19.87 ms (Horizontal Line Time) x (lines in frame + 51) — in μs	
Auto-Exposure	Yes, with Auto-Brightness Target	
Black offset control	Yes (in DN)	
Gain Control	Yes (256 max)	
Color Enhancement Support	Monochrome Model – No	Color Model – Yes (Brightness, Contrast, Gamma)
Defective Pixel Replacement	Yes	
Image Correction	No	
Image Flip Support	Yes, on sensor, vertical and horizontal	
Binning Support	Yes, monochrome model	
Multi-ROI Support	No	
Decimation Support	Yes, $\frac{1}{2}\text{x}$ vertical and horizontal	
On-Board Image Memory	128 MB	
Output Dynamic Range (dB)	72.4 dB	
SNR	44.0 dB	

3.8.1 Quantum Efficiency Curves (IMX428)

The response curves describe the sensor, excluding lens and light source characteristics.

Models – Monochrome

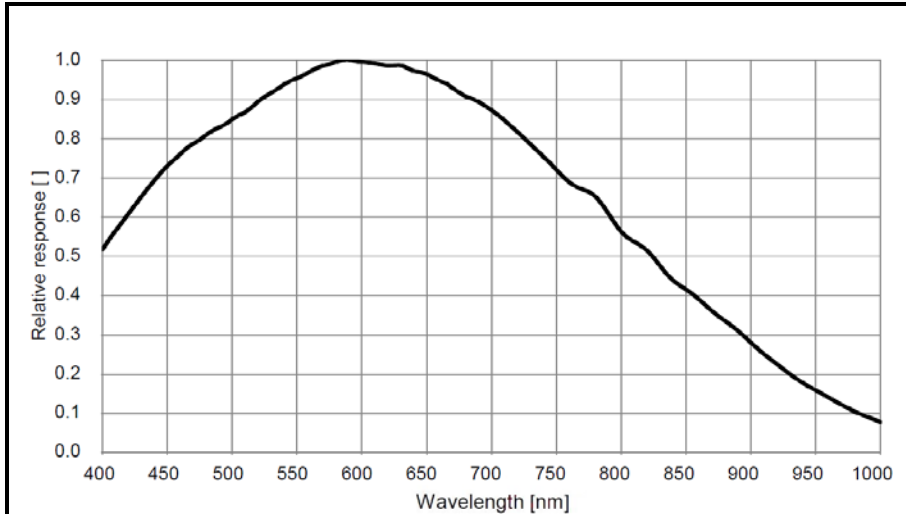

Models – Color

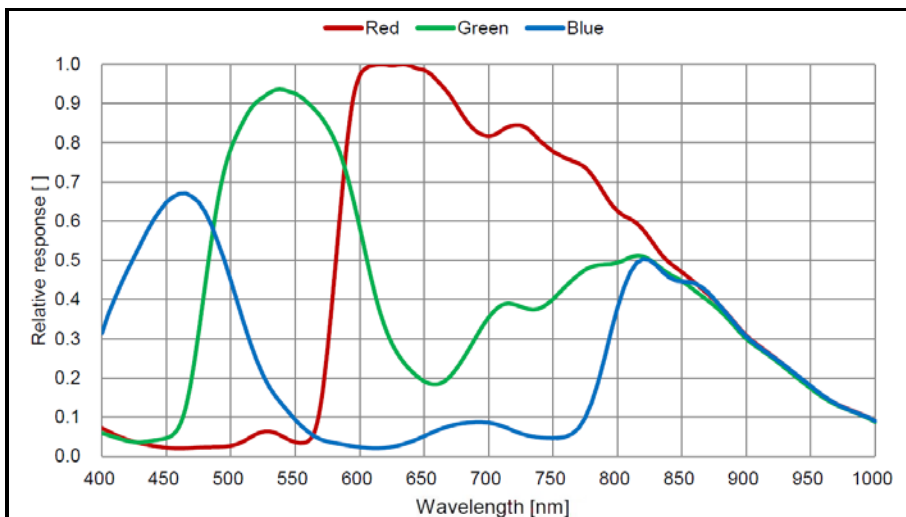

3.9 Specifications: Lt-M3840 / Lt-C3840

Supported Features	Lt-M3840 / Lt-C3840	
Resolution	3840 x 2160	
Sensor	Sony IMX334 (8.3 MP)	
Pixel Size	2 μm x 2 μm	
Optical Format	1/1.8"	
Shutter type (see Sensor Control Feature Descriptions)	Rolling shutter function (continuous) with Global Reset Release (GRR) function (External Trigger single exposure)	
Full Well charge	7.0 ke (max)	
Pixel Data Formats	Monochrome 8-bit or 12-bit	Bayer 8-bit or 12-bit
Max. Internal Frame Rate Full resolution	44 fps (8-bit, 12-bit)	
Maximum Sustained Frame Rate Output	44 fps (8-bit)	
Exposure Time Range	104 μs – 1 s (triggered) 13 μs – 1 s (continuous)	
Trigger to Exposure Minimum delay	1 μs	
Actual Exposure Time Minimum	103.70 μs (triggered) 12.21 μs (continuous) (Exposure time increment steps = Horizontal Time Line)	
Min. Time from End of Exposure to Start of Next Exposure	29.6 μs	
Horizontal Line Time	14.81 μs (triggered) 9.91 μs (continuous)	
Readout Time	32.00 ms (triggered) 21.41 ms (continuous) (Horizontal Line Time) x (lines in frame) – in μs	
Auto-Exposure	Yes, with Auto-Brightness Target (continuous only)	
Black offset control	Yes (in DN)	
Gain Control	Yes (1x to 3317x)	
Color Enhancement Support	No – Monochrome Models	Yes – Color Models (Brightness, Contrast, Gamma)
Defective Pixel Replacement	Yes	
Image Correction	No	
Image Flip Support	Yes in sensor, Vertical and Horizontal	
Binning Support	Yes, color model	
Multi-ROI Support	No	
Decimation Support	No	
On-Board Image Memory	Yes (128 MB)	
Output Dynamic Range (dB)	70.8 dB	
SNR	38.5 dB	

3.9.1 Quantum Efficiency Curves (IMX334)

The response curves describe the sensor, excluding lens and light source characteristics.

Monochrome

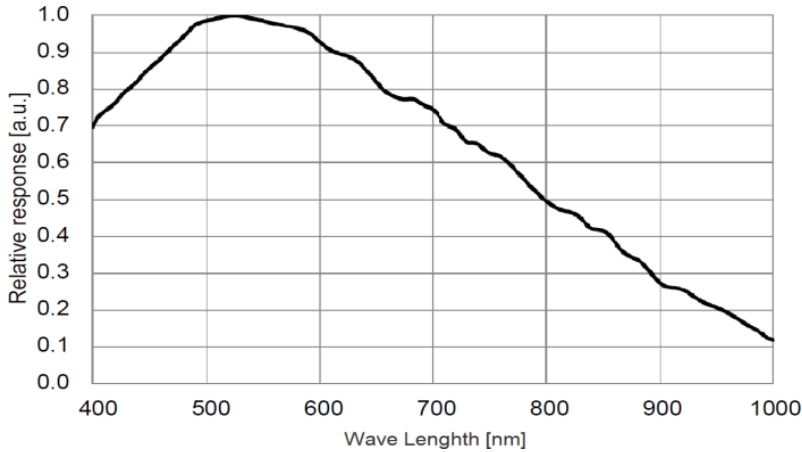

Color

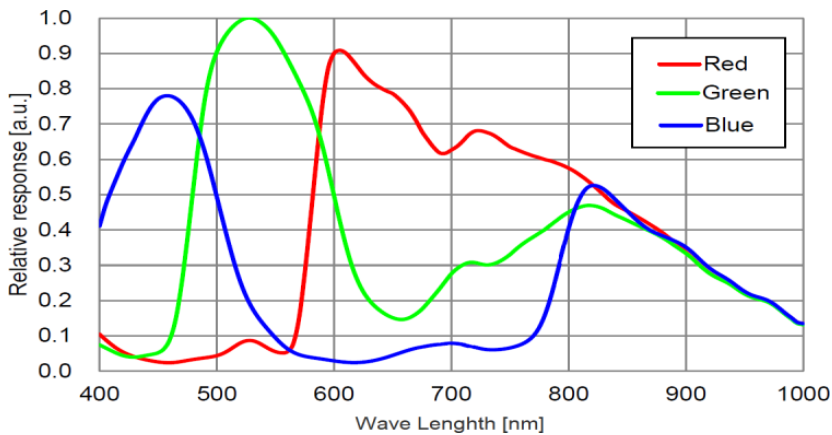

3.10 Specifications: Lt-M4030 / Lt-C4030

Supported Features	Lt-M4030 / Lt-C4030	
Resolution	4112 x 2176	
Sensor	Sony IMX267 (8.9 MP)	
Pixel Size	3.45 μm x 3.45 μm	
Optical Format	1"	
Shutter type	Full frame electronic global shutter function	
Full Well charge	10.6 ke (max)	
Pixel Data Formats	Monochrome 8-bit or 12-bit	Bayer 8-bit or 12-bit
Max. Internal Frame Rate Full resolution	31 fps (8-bit) 21 fps (12-bit)	
Maximum Sustained Frame Rate Output	31 fps (8-bit)	
Exposure Time Range	14 μs – 4295 s (triggered) 14 μs – 22.8 s (continuous)	
Trigger to Exposure Minimum delay	1 μs	
Actual Exposure Time Minimum	14.26 μs (Exposure time increment steps = Horizontal Time Line)	
Min. Time from End of Exposure to Start of Next Exposure	115.5 μs	
Horizontal Line Time	14.40 μs	
Readout Time	31.33 ms (triggered) 31.61 (continuous) (Horizontal Line Time) x (lines in frame + 19) — in μs	
Auto-Exposure	Yes, with Auto-Brightness Target	
Black offset control	Yes (in DN)	
Gain Control	Yes (1.0x to 256x)	
Color Enhancement Support	No – Monochrome Models	Yes – Color Models (Brightness, Contrast, Gamma)
Defective Pixel Replacement	Yes	
Image Correction	No	
Image Flip Support	Yes in sensor, Vertical and Horizontal	
Binning Support	No	
Multi-ROI Support	No	
Decimation Support	Yes, 1/2x vertical and horizontal	
On-Board Image Memory	Yes (128 MB)	
Output Dynamic Range (dB)	73.3 dB	
SNR	40.1 dB	

3.10.1 Quantum Efficiency Curves (IMX267)

The response curves describe the sensor, excluding lens and light source characteristics.

Monochrome

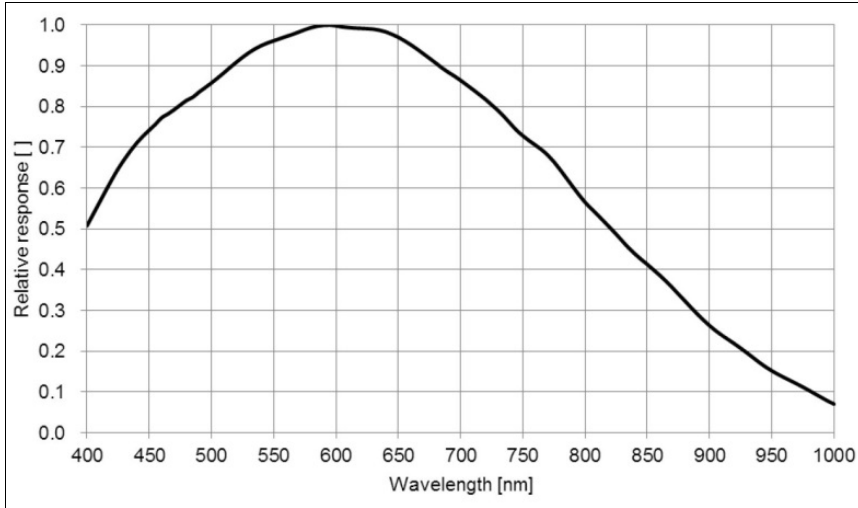

Color

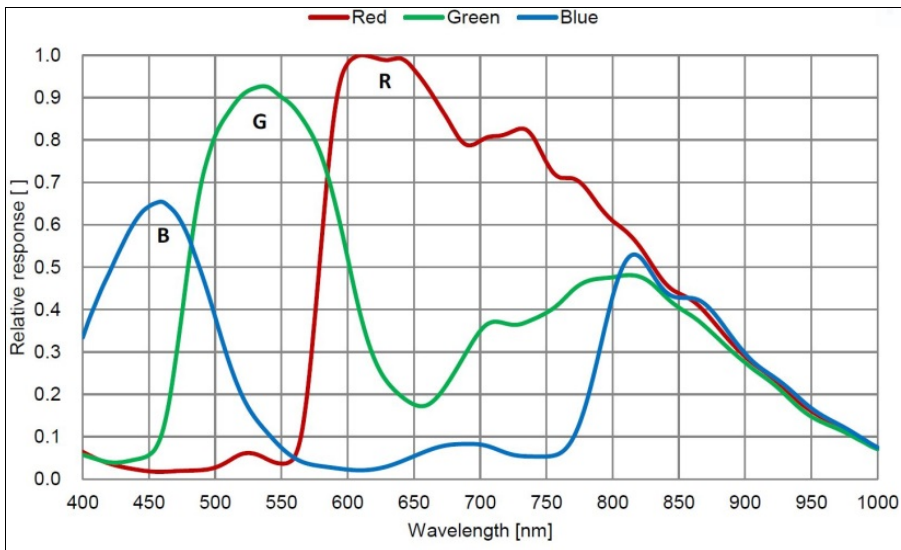

3.11 Specifications: Lt-M4020 / Lt-C4020

Supported Features	Lt-M4020 / Lt-C4020	
Resolution	4112 x 3008	
Sensor	Sony IMX304 (12.4 MP)	
Pixel Size	3.45 μm x 3.45 μm	
Optical Format	1.1"	
Shutter type	Full frame electronic global shutter function	
Full Well charge	10.6 ke (max)	
Pixel Data Formats	Monochrome 8-bit or 12-bit	Bayer 8-bit or 12-bit
Max. Internal Frame Rate Full resolution	22 fps (8-bit) 15 fps (12-bit)	
Maximum Sustained Frame Rate Output	22 fps (8-bit)	
Exposure Time Range	14 μs – 4295 s (triggered) 14 μs – 22.8 s (continuous)	
Trigger to Exposure Minimum delay	1 μs	
Actual Exposure Time Minimum	14.26 μs (Exposure time increment steps = Horizontal Time Line)	
Min. Time from End of Exposure to Start of Next Exposure	115.5 μs	
Horizontal Line Time	14.40 μs	
Readout Time	43.80 ms (triggered) 43.59 ms (continuous) (Horizontal Line Time) x (lines in frame + 19) — in μs	
Auto-Exposure	Yes, with Auto-Brightness Target	
Black offset control	Yes (in DN)	
Gain Control	Yes (1.0x to 256x)	
Color Enhancement Support	No – Monochrome Models	Yes – Color Models (Brightness, Contrast, Gamma)
Defective Pixel Replacement	Yes	
Image Correction	No	
Image Flip Support	Yes in sensor, Vertical and Horizontal	
Binning Support	No	
Multi-ROI Support	No	
Decimation Support	Yes, 1/2x vertical and horizontal	
On-Board Image Memory	Yes (128 MB)	
Output Dynamic Range (dB)	73.0 dB	
SNR	40.1 dB	

3.11.1 Quantum Efficiency Curves (IMX304)

The response curves describe the sensor, excluding lens and light source characteristics.

Monochrome

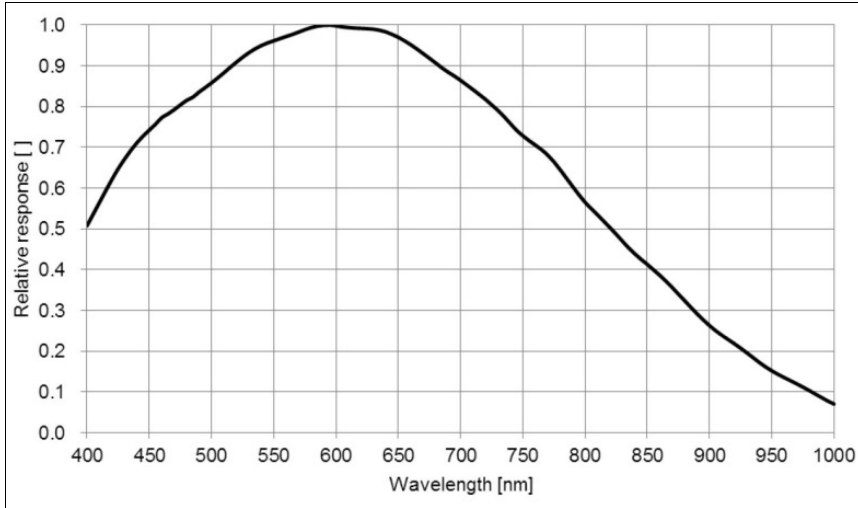

Color

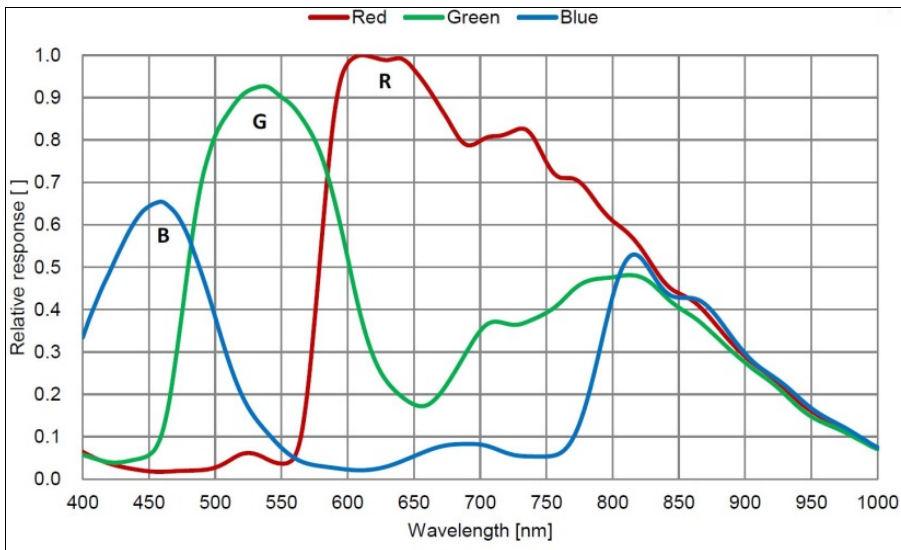

3.12 Specifications: Lt-M5500 / Lt-C5500

Supported Features	Lt-M5500 / Lt-C5500	
Resolution	5472 x 3648	
Sensor	Sony IMX183 (20.0 MP)	
Pixel Size	2.40 μm x 2.40 μm	
Optical Format	1"	
Shutter type	Electronic Rolling Shutter (ERS) function (continuous) Global Reset Release (GRR) function (single exposure)	
Full Well charge	14.6 ke	
Pixel Data Formats	Monochrome 8-bit or 12-bit	Bayer 8-bit or 12-bit
Max. Internal Frame Rate Full resolution	20 fps (8-bit, 12-bit)	
Maximum Sustained Frame Rate Output	20 fps (8-bit)	
Exposure Time Range	1773 μs – 10 s (triggered) 57 μs – 1 s (continuous)	
Trigger to Exposure Minimum Delay	1 μs	
Actual Exposure Time Minimum	1772.44 μs (triggered) 57.44 μs (continuous) (Exposure time increment steps = Horizontal Time Line)	
Min. Time from End of Exposure to Start of Next Exposure	13.6 μs	
Horizontal Line Time	13.61 μs	
Readout Time	41.40 ms (triggered) 49.65 ms (continuous) (Horizontal Line Time) x (lines in frame) — in μs	
Auto-Exposure	Yes, with Auto-Brightness Target	
Black offset control	Yes (in DN)	
Gain Control	180 (max)	
Color Enhancement Support	Monochrome – No	Color – Yes (Brightness, Contrast, Gamma)
Defective Pixel Replacement	Yes	
Image Correction	No	
Image Flip Support	Yes, on sensor, vertical and horizontal	
Binning Support	Yes, in-sensor, continuous	
Multi-ROI Support	No	
Decimation Support	No	
On-Board Image Memory	128 MB	
Output Dynamic Range (dB)	71.7 dB	
SNR	41.7 dB	

3.12.1 Quantum Efficiency Curves (IMX183)

The response curves describe the sensor, excluding lens and light source characteristics.

Models – Monochrome

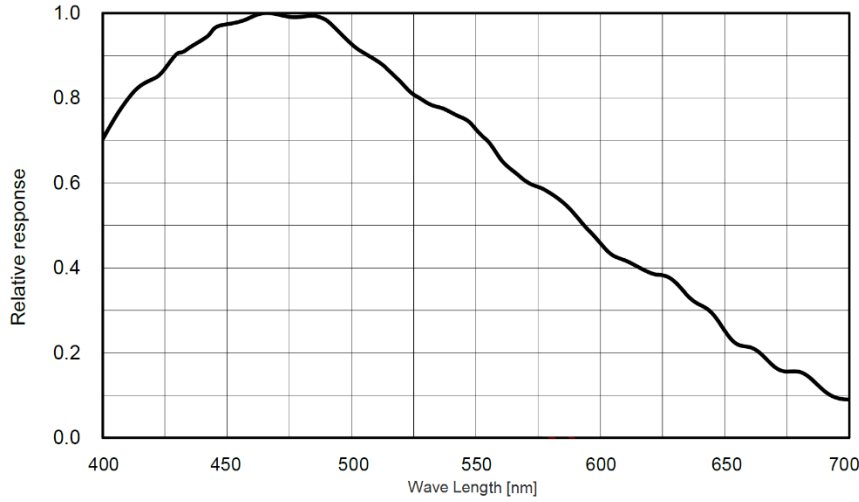

Models – Color

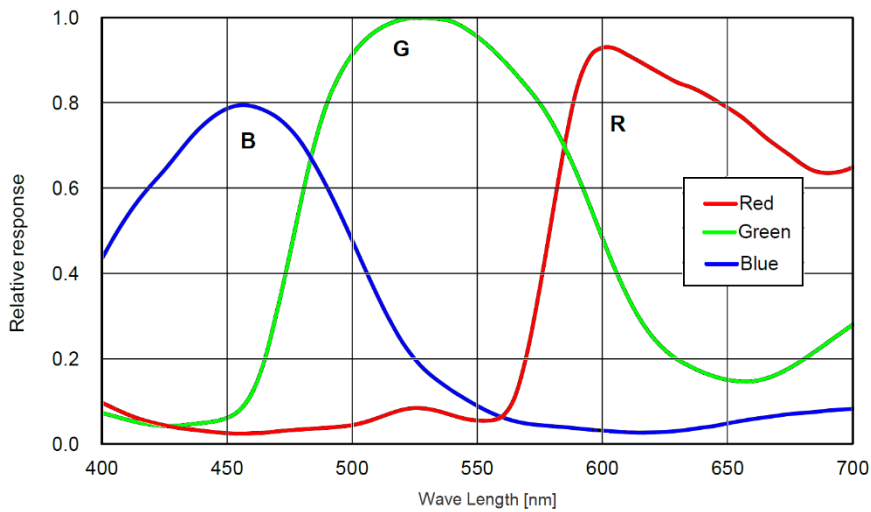

3.13 Guide to Using a Rolling Shutter Camera

A few Lt Series cameras implement Sony rolling shutter sensors to achieve a high pixel density – low cost solution for a number of imaging implementations. These sensors have different usage characteristics and thus provide different application solutions compared to the Lt Series global shutter models. The following points highlight those differences:

Simpler Sensor Design Attributes

- Rolling shutter cameras have a simpler design with smaller pixels, allowing higher resolutions for a given sensor physical area. As an example, mobile phones use rolling shutter sensors.
- Depending on the imaging requirements, the higher density pixel array may require a higher quality lens. Lens specifications define the Resolution and Contrast/Modulation attributes which must be considered. This commonly used gauge is the Modulation Transfer Function (MTF) which is extensively covered by lens suppliers to qualify their products. Consider reading <https://www.edmundoptics.com/resources/application-notes/optics/introduction-to-modulation-transfer-function/> as an initial start to understanding MTF.
- A rolling shutter sensor exposes, samples, and reads out sequentially, as part of the design criteria to achieve a higher pixel density via simplified circuitry.
- Rolling shutter sensors generate less heat which translates to a lower noise level (SNR).
- Global shutter CMOS sensors require more complicated circuit architecture, thus limiting the pixel density for a given physical size.

Rolling Shutter Trade-offs

When selecting a rolling shutter camera, the user needs to understand that the camera is not suitable for all machine vision applications. Limitation examples are:

- A rolling shutter camera is unsuitable for applications like barcode scanning, machine vision, or automated inspection systems, which require the imaging of rapidly moving objects.
- Moving objects are subject to temporal distortions best described as positional errors (shifts) from the top of an object to its bottom, due to how individual lines are exposed (detailed below).
- Rolling shutter cameras using Global Reset Release (GRR) mode are not suitable for moving objects in well-lit environments.
- The degree of distortions change as exposure time is increased or decreased.
- The use of a strobe flash with a controlled duration, in a dark imaging environment, is required to eliminate positional distortions.
- The Internet has many sources and examples of the visual distortions due to Rolling Shutter sensors, mostly in reference to using cell phones and consumer cameras, for instance (e.g. <https://www.youtube.com/watch?v=dNVtMmLinoE> *Rolling Shutter Explained (Why Do Cameras Do This?)*)

The guidelines that follow will permit the successful usage of rolling shutter cameras in machine vision applications.

Guide to ERS or GRR Exposure Modes

The following two sections provide overviews and constraints on using either the typical *Electronic Rolling Shutter (ERS) Exposures* or *Global Reset Release (GRR) Exposures* modes.

3.13.1 Overview of Electronic Rolling Shutter (ERS) Exposures

Referring to the following graphic:

- Each sensor line is exposed for the programmed time integration period.
- Exposures start with Line 1. The sensor design uses a shared line readout circuit. Due to this simplified circuitry, only a single line of pixel data can be readout at any given time. Therefore, the Line 2 exposure (integration period) is delayed by the required readout time of Line 1.
- This delayed line exposure is repeated from the sensor’s first line to its last sensor line.
- This sequence allows the common readout circuit to read the data from each row. This results in an exposure start time delay between the first to last row – thus the name rolling shutter.
- To avoid motion artifacts the user needs to freeze motion using flash lighting of suitable length in a dark environment. The flash is triggered at the start of the last line’s exposure and stops at the end of the first line’s exposure. The flash must maintain a constant light output during this period.
- To control the flash device, use the Lumenera Lt output signal with these feature selections: `outputLineSource=PulseOnStartofExposure`, `outputLinePulseDelay=flashZoneDelay` (delay to the start of the last line exposure), `outputLinePulseDuration=flashZoneDuration` (optimal flash zone time as shown in the graphic below).
- The two new features mentioned, `flashZoneDelay` and `flashZoneDuration`, automatically provide the optimal flash zone time values no matter the exposure duration and any vertical cropping/offset settings. The user is free to use any delay or duration as required. See **Strobe and Flash Zone (Lt-3840, Lt-5500)** for settings.
- The dark environment illumination ensures minimal exposure (and thus minimal motion artifacts) during the sensor lines integration time occurring before and after the flash period.

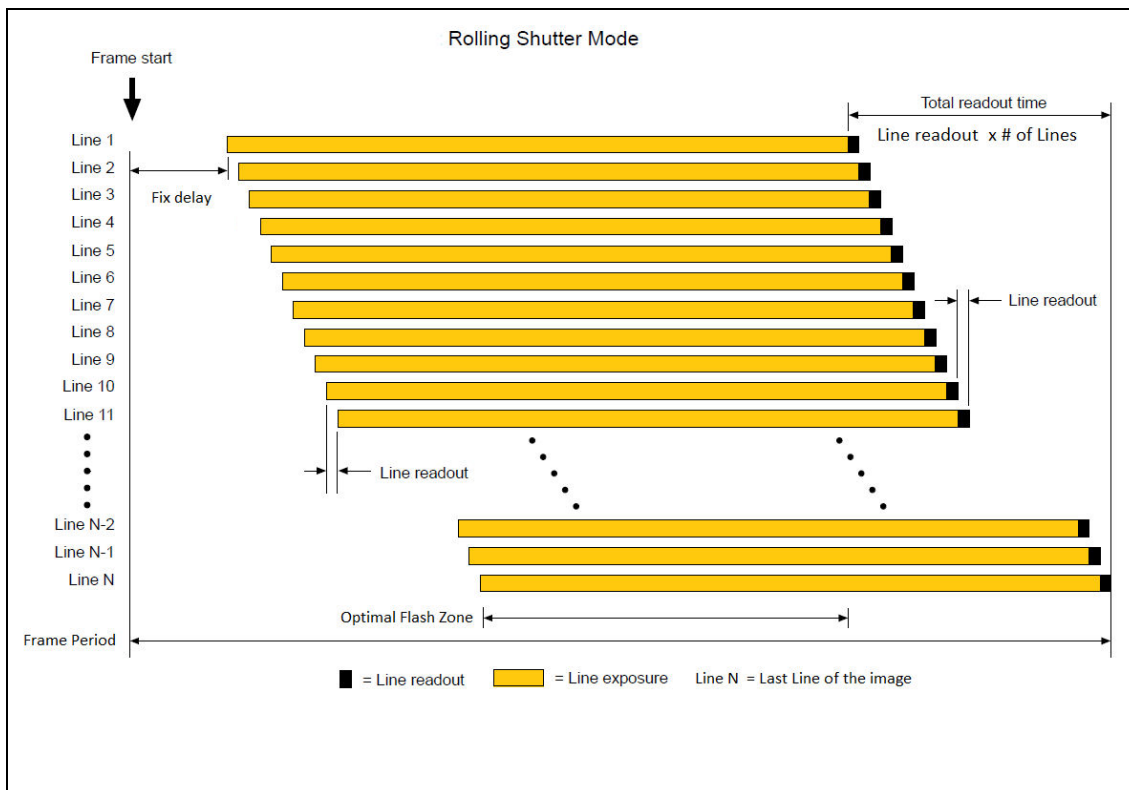

3.13.2 Overview of Global Reset Release (GRR) Exposures

Referring to the following graphic:

- All sensor lines start integrating at the same time, therefore GRR mode is also known as Global Start Mode.
- The first sensor line (Line 1) only is exposed for the programmed time integration period.
- The sensor design uses a shared line readout circuit. Therefore again, only a single line of pixel data can be readout at any given time.
- With each sensor line starting exposure integration at once, each following line's exposure is increased by the readout time required by the previous row.
- In a well-lit environment with static objects, there is a visible exposure increase from the top sensor row to the bottom sensor row.
- With moving objects in a well-lit environment, there is motion blurring from top to bottom.
- Therefore, as described previously, flash lighting in a dark environment is used to freeze motion. The flash period matches the integration period for Line 1. The increasing exposures for the other sensor lines will not be visible without any other illumination source.

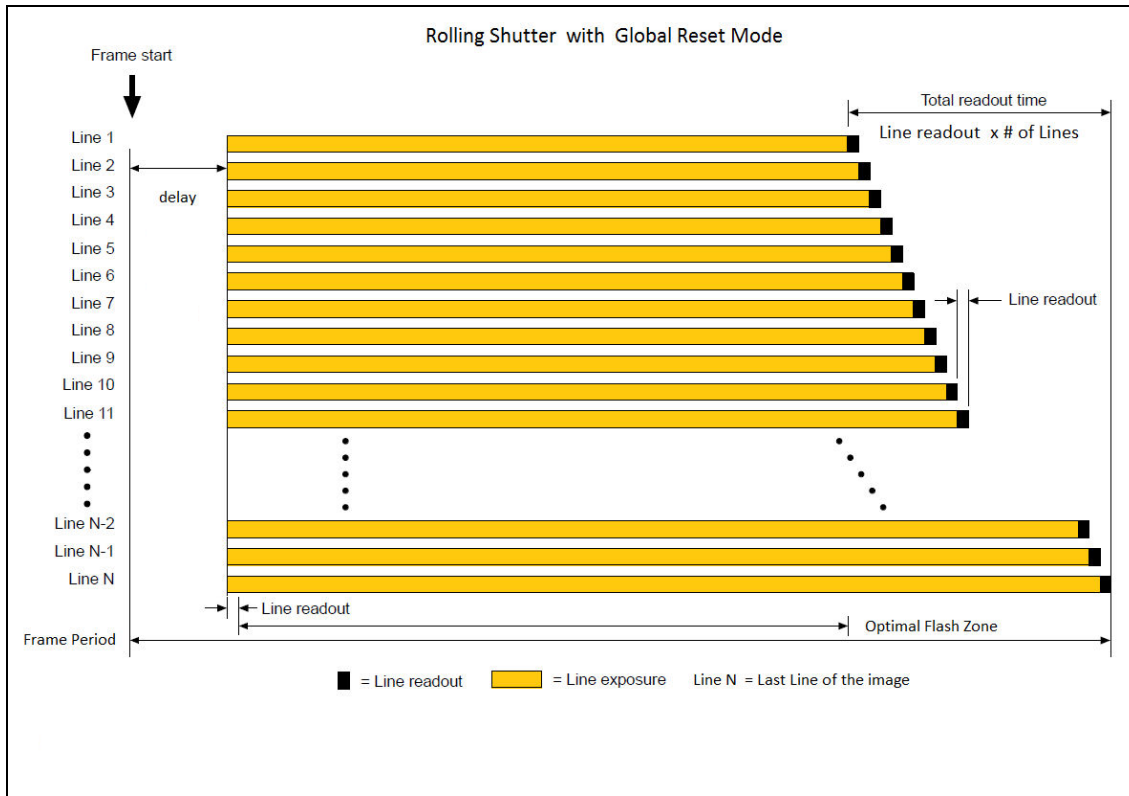

4 Connecting the Camera

4.1 USB Vision Overview

Ratified in 2013, the USB Vision standard is a popular interface for industrial cameras connected to computer systems. Teledyne LUMENERA USB3 cameras comply with the standard as defined by the USB Vision Technical Committee of the Automated Imaging Association (www.visiononline.org).

The AIA USB3 Vision implementation uses the programming interface (API) previously defined by the GenICam™ standard for access and control features in compliant imaging products, which simplifies applications design and integration (device discovery, device control, event handling, data streaming, etc.) for camera and system manufacturers.

For viability in real world machine vision environments, the standard also specifies locking USB 3 compliant connectors such as the USB 3.0 Standard-B and USB 3.0 Powered-B connector.

See **Switching a Lumenera camera from LuCam mode to USB3 Vision mode** to use cameras with the Sopera LT development environment.

4.2 Connecting Power

Simple setups have a Lt Series camera powered directly by the USB3 port. This method provides a cabling solution for testing or for imaging installations where camera acquisitions are only software controlled and require no external I/O.

Alternatively, if the camera is connected to USB2, camera power is supplied via the power pins on the I/O connector. See section **I/O Connector Pinout Details** for the I/O connector and power supply specifications.

When the camera receives power, the status LED (adjacent to the I/O connector) will be Yellow then Green signaling that the camera has initialized and is ready.

4.2.1 Connectors

The camera has three connectors:

- **USB3:** USB3 connection to a computer which can also supply camera power.
- **I/O Signals and Alternative Power:** Used for external signal connections and for camera power if the USB3 connection cannot supply the requirement.

The following figures of the camera back side shows connector and LED locations. See chapter **Technical Specifications** for details on the connectors and camera mounting dimensions.



Teledyne Lumenera LT-xx1x-xxxxx Series – Rear View

4.2.2 LED Status Indicator

The Lt Series has one multicolor LED located on the back panel, to provide a simple visible indication of camera state, as described below.

LED State	Definition
LED is off	No power to the camera
Solid Orange	Device driver failed to load
Blinks orange few times per second	Firmware failed to load
Blinks orange once per 2 seconds	FPGA failed to load.
Solid green	Camera ready / operational
Dimmer green	Camera is streaming or fast frames mode is enabled
Dimmer green (snapshot)	LED will be dimmer green for duration of exposure
Blink orange/green	(case 1) Camera is connected to USB 2.0 ports and does not have external power connected. (case 2) USB3 port is not supplying enough camera power.

4.3 Preventing Operational Faults due to ESD

	<p>Camera installations which do not protect against ESD (electrostatic discharge) may exhibit operational faults. Problems such as random camera resets and random loss of connections may all be solved by proper ESD management. The camera when used with USB3 power or a simple power supply is not properly connected to earth ground and therefore is susceptible to ESD caused problems.</p>
---	--

Teledyne LUMENERA has performed ESD testing on cameras using an 8 kilovolt ESD generator without any indication of operational faults. The two following methods, either individually or together will prevent ESD problems.

- Method 1: Use a shielded/grounded power supply that connects to the ground pin of the I/O connector. The camera body is now properly connected to earth ground and can withstand ESD of 8 kilovolts.
- Method 2: Mount the camera on a metallic platform with a good connection to earth ground.

5 Feature Reference

5.1 Lt Series Features

The Teledyne Lumenera Lt Camera series feature set is presented in functional categories as grouped by the camera's XML file. The USB3 GenICam control tool presents these features for the user to read or modify as required to explore the camera operation in the user's imaging setup. Typically, this is followed by a program written to control the camera in an automated measurement application.

5.2 Camera Information Category

Camera information is retrieved via a controlling application. USB3 Vision applications retrieve this information to identify the camera along with its characteristics. Parameters such as camera model, firmware version, etc. are read to uniquely identify the connected device. These features are typically read-only.

Features listed in the description table but tagged as *Invisible* are usually for third party software usage—not typically needed by end user applications.

Category	Parameter	Value
Camera Information	Device Vendor Name	Teledyne Lumenera
Sensor Control	Device Model Name	Lt-C2020
I/O Control	Device Version	1.00
<input type="checkbox"/> Advanced Processing	Manufacturer Part Number	
Color Processing	Device Manufacturer Info	Teledyne Lumenera
Image Format Control	Device Firmware Version	Firmware Version:00414 FPGA: 00055
Acquisition Control	Device Serial Number	0020030313
<input type="checkbox"/> Event Control	Device User ID	AcmeFramus
<input type="checkbox"/> Event Info	Device Reset	Press...
Test Data	Device Temperature (in C)	41.416
Exposure End Data	Power-up Configuration	Setting...
Transport Layer Control	<< Less	
Teledyne Lumenera Control		
File Access Control		
USB3 Vision Host Controls		

5.2.1 Camera Information Feature Descriptions

The following table describes the features and values found in the category, as well as the device version and visibility level (beginner, expert, guru, invisible). The device version represents a camera software functional level (different from the firmware revision number) and may differ for each camera sensor. A major device version release is shown in **green**. The last column also indicates whether the feature is a member of the DALSA Features Naming Convention (DFNC) or the GenICam Standard Features Naming Convention (SFNC, tag not shown).

Display Name	Feature & Values	Description	Device Version & View
Device Vendor Name	DeviceVendorName	Name of the manufacturer of the device.	1.00 Beginner
Device Model Name	DeviceModelName	Model of the device.	1.00 Beginner
Device Version	DeviceVersion	Version of the device.	1.00 Beginner
Manufacturer Part Number	deviceManufacturerPartNumber	Displays the device manufacturer part number.	1.00 DFNC Beginner
Manufacturer Info	DeviceManufacturerInfo	Manufacturer information about the device.	1.00 Beginner
Device Firmware Version	DeviceFirmwareVersion	Version of the firmware in the device.	1.00 Expert
Device Serial Number	DeviceSerialNumber	Device's serial number. This string is a unique identifier of the device.	1.00 Beginner
Device User ID	DeviceUserID	User-programmable device identifier.	1.00 Beginner
Device Reset	DeviceReset	Resets the device to its power up state. After reset, the device must be rediscovered.	1.00 Beginner
Device Temperature	DeviceTemperature	Device's sensor temperature in degrees Celsius I.	1.00 Expert
Device Gen CP Version Major	DeviceGenCPVersionMajor	Major version of the GenCP specification.	1.00 Invisible
Device Gen CP Version Minor	DeviceGenCPVersionMinor	Minor version of the GenCP specification.	1.00 Invisible
Device Manifest XML Major Version	DeviceManifestXMLMajorVersion	Indicates the major version number of the GenICam XML.	1.00 Invisible
Device Manifest XML Minor Version	DeviceManifestXMLMinorVersion	Indicates the minor version number of the GenICam XML.	1.00 Invisible
Device Manifest XML Sub Minor Version	DeviceManifestXMLSubMinorVersion	Indicates the subminor version number of the GenICam XML.	1.00 Invisible

5.3 Sensor Control Category

These Lt Series controls group sensor specific parameters such as frame rate, exposure time & mode, gain, etc. Parameters shown on screen in gray are read only, either always or due to other feature settings.

Features listed in the description table that are tagged as *Invisible* are usually for third party software usage—not typically needed by end user applications. Note that features shown may change with different camera models implementing different sensors, image resolutions and color versions.

Category	Parameter	Value
Camera Information	Sensor Shutter Mode	Global
Sensor Control	Auto-Brightness Target	152
I/O Control	Acquisition Frame Rate Control Mode	Maximum Speed
<input type="checkbox"/> Advanced Processing	Acquisition Frame Rate (in Hz)	55.555557
Color Processing	Exposure Time (in us)	9995.0
Image Format Control	Exposure Auto	Off
Acquisition Control	Auto-Exposure Time Max Value (in us)	100000.0
<input type="checkbox"/> Event Control	Exposure Mode	Timed
<input type="checkbox"/> Event Info	Exposure Alignment	Synchronous
Test Data	Gain Selector	All
Exposure End Data	Gain	1.0
Transport Layer Control	Gain Auto	Off
Teledyne Lumenera Control	Auto-Gain Max Value	256.0
File Access Control	Auto-Gain Min Value	1.0
USB3 Vision Host Controls	Black Level Selector	Analog
	Black Level (in DN)	5.0
	Black Level Auto	Continuous

5.3.1 Sensor Control Feature Descriptions

The following table describes the features and values found in the category, as well as the device version and visibility level (beginner, expert, guru, invisible). The device version represents a camera software functional level (different from the firmware revision number) and may differ for each camera sensor. A major device version release is shown in green. The last column also indicates whether the feature is a member of the DALSA Features Naming Convention (DFNC) or the GenICam Standard Features Naming Convention (SFNC, tag not shown).

Display Name	Feature & Values	Description	Device Version & View
Sensor Shutter Mode	SensorShutterMode	States or selects the supported shutter mode of the device.	1.00 Beginner
<i>Global</i>	<i>Global</i>	<i>The shutter exposes all pixels at the same time.</i>	

Display Name	Feature & Values	Description	Device Version & View
<i>Global Reset</i>	<i>GlobalReset</i>	<i>The shutter opens at the same time for all pixels but ends in a line sequential manner.</i>	
<i>Rolling</i>	<i>Rolling</i>	<i>The shutter opens and closes sequentially for groups (typically lines) of pixels.</i>	
Auto-Brightness Target	autoBrightnessTarget	Sets the target image grayscale value in DN, for the auto-brightness algorithm. Features that use auto-brightness include ExposureAuto and GainAuto.	1.00 DFNC Expert
Acquisition Frame Rate Control Mode	acquisitionFrameRateControlMode	Set the frame control method used in free running mode.	1.00 DFNC Guru
<i>Programmable</i>	<i>Programmable</i>	<i>The camera frame rate is controlled by the AcquisitionFrameRate feature.</i>	
<i>MaximumSpeed</i>	<i>MaximumSpeed</i>	<i>The camera operates at its maximum frame rate using the current exposure (time and delay) configuration.</i>	
Acquisition Frame Rate	AcquisitionFrameRate	Controls the acquisition rate (in Hertz) at which the frames are captured.	1.00 Beginner
Exposure Time	ExposureTime	Sets the Exposure time. This controls the duration where the photosensitive cells are exposed to light.	1.00 Beginner
Exposure Auto	ExposureAuto	Sets the automatic exposure mode. The exact algorithm used to implement this control is device-specific.	1.00 Beginner
<i>Off</i>	<i>off</i>	<i>Exposure duration is user controlled using ExposureTime.</i>	
<i>Continuous</i>	<i>Continuous</i>	<i>Exposure duration is constantly adapted by the device to maximize the dynamic range.</i>	
Auto-Exposure Time Max Value	exposureAutoMaxValue	Sets the maximum exposure time value allowed by the user in microseconds for the Auto-Exposure function.	1.00 DFNC Expert
Exposure Mode	ExposureMode	Sets the operation mode for the camera exposure (or electronic shutter).	1.00 Beginner
<i>Timed</i>	<i>Timed</i>	<i>The exposure duration time is set using the Exposure Time feature and the exposure starts with a FrameStart event.</i>	
Exposure Alignment	exposureAlignment	Exposure Alignment specifies how the exposure is executed in relationship to the sensor capabilities and current frame trigger.	1.00 DFNC Expert
<i>Synchronous</i>	<i>Synchronous</i>	<i>Exposure is synchronous to the internal timing of the sensor. The readout is concurrent to the exposure for the fastest possible frame rate. When a valid trigger is received and the ExposureTime is shorter than the readout period, the ExposureStart event is latched in the previous frame's readout. That is; the ExposureStartEvent is delayed and is initiated when the actual exposure starts such that the exposure ends and readout begins as soon as the previous readout has completed.</i>	
<i>Reset</i>	<i>Reset</i>	<i>Sensor timing is reset to initiate exposure when a valid trigger is received. Readout is sequential to exposure, reducing the maximum achievable frame rates. That is, a trigger received during exposure or readout is ignored since data would be lost by performing a reset.</i>	
Gain Selector	GainSelector	Selects which gain is controlled when adjusting gain features.	1.00 Beginner
<i>All</i>	<i>All</i>	<i>Gain will be applied to all channels or taps.</i>	

Display Name	Feature & Values	Description	Device Version & View
High Gain Conversion Mode	HighGainConversionMode	Sets the high gain conversion mode.	1.01 DFNC Guru (model dependent)
<i>Off</i>	<i>Off</i>	High gain conversion mode is disabled.	
<i>Active</i>	<i>Active</i>	High gain conversion mode is enabled.	
Gain	Gain	Controls the selected gain as an amplification factor.	1.00 Beginner
Gain Auto	GainAuto	Sets the automatic gain control (AGC) mode. The exact algorithm used to implement AGC is device-specific.	1.00 Beginner
<i>Off</i>	<i>Off</i>	<i>Gain is User controlled using Gain.</i>	
<i>Continuous</i>	<i>Continuous</i>	<i>Gain is constantly adjusted by the device.</i>	
Auto-Gain Max Value	gainAutoMaxValue	Sets the maximum gain multiplier value for the automatic gain algorithm. The automatic gain function is an amplification factor applied to the video signal to obtain the auto-brightness target value.	1.00 DFNC Guru
Auto-Gain Min Value	gainAutoMinValue	Sets the minimum gain multiplier value for the automatic gain algorithm. The automatic gain function is an amplification factor applied to the video signal to obtain the auto-brightness target value.	1.00 DFNC Guru
Black Level Selector	BlackLevelSelector	Selects which Black Level to adjust using the Black Level features.	1.00 Expert
<i>Analog</i>	<i>AnalogAll</i>	<i>Sensor Dark Offset</i>	
Black Level	BlackLevel	Controls the black level as an absolute physical value. This represents a DC offset applied to the video signal, in DN (digital number) units. The Black Level Selector feature specifies the channel to adjust.	1.00 Expert
Black Level Auto	BlackLevelAuto	Sets the automatic black level control mode.	1.00 Expert
<i>Off</i>	<i>Off</i>	<i>Black Level is User controlled using Black Level.</i>	
<i>Continuous</i>	<i>Continuous</i>	<i>Black level is programmed automatically from other settings.</i>	

5.3.2 High gain conversion mode

High gain conversion mode is used to improve image quality in low light environments.

When high gain conversion is enabled (**High Gain Conversion Mode** = *Active*), read noise is minimized, which yields a lower absolute sensitivity threshold better suited for detecting weak signals with short exposures. This mode is therefore ideal when light levels are low.

In normal to very bright lighting conditions, the saturation capacity of the sensor pixels should be maximized to provide the highest dynamic range. In this case, the high gain conversion mode should be disabled (**High Gain Conversion Mode** = *Off*).

5.4 I/O Control Category

The Lumenera I/O control has features used to configure external trigger and line inputs plus strobe output configuration. Parameters in gray are read only, either always or due to another parameter being disabled. Parameters in black are user set or programmable via an imaging application.

Features listed in the description table but tagged as *Invisible* are usually for third party software usage—not typically needed by end user applications. Also important, cameras are available in a number of models implementing different sensors which may support different features within this category.

Category	Parameter	Value
Camera Information	Trigger Selector	Single Frame Trigger(Start)
Sensor Control	Trigger Mode	Off
I/O Control	Trigger Software	Press...
<input type="checkbox"/> Advanced Processing	Trigger Source	Software
Color Processing	Trigger Activation	Rising Edge
Image Format Control	Trigger Delay (in us)	0.0
Acquisition Control	Trigger Frames Count	1
<input type="checkbox"/> Event Control	Strobe Mode	Off
<input type="checkbox"/> Event Info	Strobe Delay (in us)	0
Test Data	Strobe Duration (in us)	41
Exposure End Data	Strobe Source	Line 1
Transport Layer Control	Line Selector	Line 0
Teledyne Lumenera Control	Line Name	GPI1 Opto
File Access Control	Line Mode	Input
USB3 Vision Host Controls	Line Inverter	Not Enabled
	Line Status	False
	Output Line Source	Not Enabled
	Output Line Value	Not Enabled
	Line Status All	0x0000000000000000C
	<< Less	

5.4.1 I/O Control Feature Descriptions

The following table describes the features and values found in the category, as well as the device version and visibility level (beginner, expert, guru, invisible). The device version represents a camera software functional level (different from the firmware revision number) and may differ for each camera sensor. A major device version release is shown in green. The last column also indicates whether the feature is a member of the DALSA Features Naming Convention (DFNC) or the GenICam Standard Features Naming Convention (SFNC, tag not shown).

Display Name	Feature & Values	Description	Device Version & View
Trigger Selector	TriggerSelector	Selects which type of trigger to configure with the various Trigger features.	1.00 Beginner
Single Frame Trigger(Start)	FrameStart	Selects a trigger starting the capture of a single frame. Frame size is determined by image format feature "Height".	
MultiFrame Trigger(Start)	FrameBurstStart	Selects a trigger to capture multiple frames. The number of frames is specified by the triggerFrameCount feature.	
Trigger Mode	TriggerMode	Controls if the selected trigger is active.	1.00 Beginner
Off	Off	Disables the selected trigger.	
On	On	Enable the selected trigger.	
Trigger Software	TriggerSoftware	Generates an internal trigger. TriggerSource must be set to Software.	1.00 Beginner
Trigger Source	TriggerSource	Specifies the internal signal or physical input Line to use as the trigger source. The selected trigger must have its TriggerMode set to On.	1.00 Beginner
Software	Software	Specifies that the trigger source will be generated by software using the TriggerSoftware command.	
Line0	Line0	Specifies which physical line (or pin) and associated I/O control block to use as external source for the trigger signal.	
Line2	Line2	Specifies which physical line (or pin) and associated I/O control block to use as external source for the trigger signal.	
Line3	Line3	Specifies which physical line (or pin) and associated I/O control block to use as external source for the trigger signal.	
Trigger Activation	TriggerActivation	Specifies the activation mode of the trigger.	1.00 Beginner
Rising Edge	RisingEdge	Specifies that the trigger is considered valid on the rising edge of the source signal.	
Falling Edge	FallingEdge	Specifies that the trigger is considered valid on the falling edge of the source signal.	
Trigger Delay	TriggerDelay	Specifies the delay in microseconds to apply after receiving the trigger and before activating the triggerEvent.	1.00 Beginner
Trigger Frames Count	triggerFrameCount	Sets the maximum number of frames to acquire when a valid trigger is received. This feature is available when Trigger Selector = MultiFrame Trigger(Start).	1.00 Beginner
Strobe Mode	StrobeMode	Enables/disables the strobes in snapshot mode.	1.00 Beginner
Off	Off	Strobe Is Off	
On Trigger	OnTrigger	Strobe fires on the trigger.	
Strobe Delay	StrobeDelay	Trigger to strobe delay	1.00 Beginner
Strobe Duration	StrobeDuration	Strobe length	1.00 Beginner

Display Name	Feature & Values	Description	Device Version & View
Strobe Source	StrobeSource	Output physical line (pin) used to generate the strobe signal.	1.00 Guru
<i>Line 1</i>	<i>Line1</i>	<i>Line 1</i>	
<i>Line 2</i>	<i>Line2</i>	<i>Line 2</i>	
<i>Line 3</i>	<i>Line3</i>	<i>Line 3</i>	
Line Selector	LineSelector	Selects the physical line (or pin) of the external device connector to configure.	1.00 Beginner
<i>Line 0</i>	<i>Line0</i>	<i>Index of the physical line and associated I/O control block to use.</i>	
<i>Line 1</i>	<i>Line1</i>	<i>Index of the physical line and associated I/O control block to use.</i>	
<i>Line 2</i>	<i>Line2</i>	<i>Index of the physical line and associated I/O control block to use.</i>	
<i>Line 3</i>	<i>Line3</i>	<i>Index of the physical line and associated I/O control block to use.</i>	
<i>Line 4</i>	<i>Line4</i>	<i>Index of the physical line and associated I/O control block to use.</i>	
line Name	lineName	Description of the physical Pin associated with the logical line.	1.00 DFNC Beginner
<i>GPI1 Opto</i>	<i>Gpi1Opto</i>	<i>Associated with the logical line GPI1 Opto</i>	
<i>GPO1 Opto</i>	<i>Gpo1Opto</i>	<i>Associated with the logical line GPO1 Opto</i>	
<i>GPIO2</i>	<i>Gpio2</i>	<i>Associated with the logical line GPIO2</i>	
<i>GPIO3</i>	<i>Gpio3</i>	<i>Associated with the logical line GPIO3</i>	
<i>VCC3.3</i>	<i>VCC3.3</i>	<i>Associated with the logical line VCC3.3</i>	
Line Mode	LineMode	Reports if the physical Line is an Input or Output signal.	1.00 Expert
<i>Input</i>	<i>Input</i>	<i>The line is an input line.</i>	
<i>Output</i>	<i>Output</i>	<i>The line is an output line.</i>	
Line Inverter	LineInverter	Control to invert the polarity of the selected input or output line signal.	1.00 Beginner
Line Status	LineStatus	Returns the current status of the selected input or output line.	1.00 Expert
Output Line Source	outputLineSource	Selects which internal signal or event driven pulse or software control state to output on the selected output line.	1.00 DFNC Beginner
<i>Software Controlled</i>	<i>SoftwareControlled</i>	<i>The OutputLineValue feature changes the state of the output.</i>	
<i>Strobe on Trigger</i>	<i>Strobe</i>	<i>Generate a pulse on the Trigger event.</i>	
<i>Pulse on: Start of Exposure</i>	<i>PulseOnStartofExposure</i>	<i>Generate a pulse on the ExposureStart event. This option is typically used to trigger a strobe light.</i>	
<i>Pulse on: Start of Readout</i>	<i>PulseOnStartofReadout</i>	<i>Generate a pulse on the ReadoutStart event.</i>	
<i>Exposure Active</i>	<i>ExposureActive</i>	<i>Generate a signal that is active when the Exposure is active.</i>	
<i>Ready For Trigger</i>	<i>ReadyForTrigger</i>	<i>Generate a signal that is active when the camera is ready for a frame trigger.</i>	

Display Name	Feature & Values	Description	Device Version & View
Output Line Pulse Delay	outputLinePulseDelay	Sets the delay (in μ s) before the output line pulse signal. Applicable for the OutputLineSource feature.	1.00 Beginner DFNC
Output Line Pulse Duration	outputLinePulseDuration	Sets the width (duration) of the output line pulse in microseconds.	1.00 Beginner DFNC
Output Line Value	outputLineValue	Sets the output state of the selected Line if the outputLineSoftwareLatchControl = OFF. OutputLineSource must be SoftwareControlled. If the outputLineSoftwareLatchControl = Latch, the state of the pin will change with the outputLineSoftwareCmd command.	1.00 Beginner
<i>Active</i>	<i>Active</i>	<i>Sets the Output circuit to close</i>	
<i>Inactive</i>	<i>Inactive</i>	<i>Sets the Output circuit to open</i>	
Flash Zone Delay	flashZoneDelay	Returns the recommended output pulse delay, corresponding to the delay of the last line exposure start of a rolling shutter sensor, when the Output Line Source = <i>Pulse on Start of Exposure</i> . (RO)	1.01 Guru DFNC Lt-M/C3840, Lt-M/C5500
Flash Zone Duration	flashZoneDuration	Returns the recommended output pulse duration for controlling a flash device for the optimal flash zone time. (RO)	1.01 Guru DFNC Lt-M/C3840, Lt-M/C5500
Line Status All	LineStatusAll	Returns the current status of all available line signals, at time of polling, in a single bit field. The order is Line1, Line2, ...	1.00 Expert
Line Pinout	linePinAssociation	Enumeration of the physical line (or pin) on the I/O device connector.	1.00 Invisible
<i>Pin6-7=Opto Input</i>	<i>GpiOptoPin6and7</i>	<i>Pin 6 is the negative opto input and Pin 7 is the positive opto input on the I/O connector.</i>	
<i>Pin2-3=Opto Output</i>	<i>GpoOptoPin2and3</i>	<i>Pin 2 is the positive opto output and Pin 3 is the negative opto output on the I/O connector.</i>	
<i>Pin4=Signal – Pin8=Gnd – Pin1=Pwr</i>	<i>Pin4Signal_Pin8Gnd_Pin1Pwr</i>	<i>Pin 4 is the Signal, Pin 8 is the ground and Pin 1 is the common output Power on the I/O connector.</i>	
<i>Pin5=Signal – Pin8=Gnd – Pin1=Pwr</i>	<i>Pin5Signal_Pin8Gnd_Pin1Pwr</i>	<i>Pin 5 is the Signal, Pin 8 is the ground and Pin 1 is the common output Power on the I/O connector.</i>	
<i>Pin9-7=Opto Input</i>	<i>GpiOptoPin9and7</i>	<i>Pin 9 is the positive opto input and Pin 7 is the negative opto input on the I/O connector.</i>	
<i>Pin8-7=Opto Output</i>	<i>GpoOptoPin8and7</i>	<i>Pin 8 is the positive opto output and Pin 7 is the negative opto output on the I/O connector.</i>	
<i>Pin4=Signal – Pin2,6=Gnd – Pin1=Pwr</i>	<i>Pin4Signal_Pin2or6Gnd_Pin1Pwr</i>	<i>Pin 4 is the Signal, Pin 2 and 6 are the ground and Pin 1 is the common output Power on the I/O connector.</i>	
<i>Pin5=Signal – Pin2,6=Gnd – Pin1=Pwr</i>	<i>Pin5Signal_Pin2or6Gnd_Pin1Pwr</i>	<i>Pin 5 is the Signal, Pin 2 and 6 are the ground and Pin 1 is the common output Power on the I/O connector.</i>	
<i>Pin3=3.3V</i>	<i>Pin3Power</i>	<i>Pin 3 is the 3.3V optional output Power on the I/O connector.</i>	

5.4.1.1 *Input and Output Line Details*

The general purpose I/O line signals are on the GPIO connector located on the back or edge (dependent of model series) of the cameras. See section **Connectors** for details on connector pinout and I/O signal specifications.

5.4.1.2 *Strobe and Flash Zone (Lt-3840, Lt-5500)*

In the case of rolling shutter cameras, to help with settings when using a strobe light, the camera provides optimal values for the **Output Line Pulse Delay** and **Output Line Pulse Duration** features, which are found, respectively, in the **Flash Zone Delay** and **Flash Zone Duration** read-only features.

IT IS UP TO THE USER TO INPUT THOSE VALUES.

Note that these optimal values depend on camera settings, so that modifying the settings may induce changes to the flash zone values. Again, it is up to the user to re-enter the **Output Line Pulse Delay** and **Output Line Pulse Duration** values when necessary.

See section **Overview of Electronic Rolling Shutter (ERS) Exposures** for details.

To Use Strobe and Flash Zone in Video/Free Running Mode (Electronic Rolling Shutter)

1. Set **Line Selector** to *Line 3* (only option for video).
2. Set **Line Mode** to *Output*.
3. Set **Output Line Source** to *Pulse on: Start of Exposure*.
4. Set **Output Line Pulse Delay** to the value found in **Flash Zone Delay**.
5. Set **Output Line Pulse Duration** to the value found in **Flash Zone Duration**.

To Use Strobe and Flash Zone in Still/Triggered Single Frame Mode (Global Reset Release Shutter)

1. Set **Trigger Mode** to *On* to set the camera to still/single frame.
2. Set **Line Selector** to *Line 1, 2, or 3*.
3. Set **Line Mode** to *Output*.
4. Set **Output Line Source** to *Pulse on: Start of Exposure*.
5. Set **Output Line Pulse Delay** to the value found in **Flash Zone Delay**.
6. Set **Output Line Pulse Duration** to the value found in **Flash Zone Duration**.

5.5 Advanced Processing Control Category

This feature group includes controls for acquisition processing of color, gamma, LUT, etc. Parameters in gray are read only, either always or due to other feature settings. Parameters in black are user set.

Features listed in the description table that are tagged as *Invisible* are usually for third party software usage—not typically needed by end user applications.

Parameters - Visibility: Guru		
Category	Parameter	Value
Camera Information	Gamma Correction	1.0
Sensor Control	Contrast Correction	1.0
I/O Control	Brightness Correction	0.0
Advanced Processing	LUT Mode	Off
Color Processing	LUT Index	0
Image Format Control	LUT Value	
Acquisition Control	LUT Value All	
Event Control	<< Less	
Transport Layer Control		
Teledyne Lumenera Control		
File Access Control		
USB3 Vision Host Controls		

Parameters - Visibility: Guru		
Category	Parameter	Value
Camera Information	Balance White Auto	Off
Sensor Control	Balance Ratio Selector	Red
I/O Control	Balance Ratio	1.25
Advanced Processing	<< Less	
Color Processing		
Image Format Control		
Acquisition Control		
Event Control		
Transport Layer Control		
Teledyne Lumenera Control		
File Access Control		
USB3 Vision Host Controls		

5.5.1 Advanced Processing Control Feature Descriptions

The following table describes the features and values found in the category, as well as the device version and visibility level (beginner, expert, guru, invisible). The device version represents a camera software functional level (different from the firmware revision number) and may differ for each camera sensor. A major device version release is shown in green. The last column also indicates whether the feature is a member of the DALSA Features Naming Convention (DFNC) or the GenICam Standard Features Naming Convention (SFNC, tag not shown).

Display Name	Feature & Values	Description	Device Version & View
Gamma Correction	gammaCorrection	Sets the gamma correction factor. The gamma correction is applied as an inverse exponent to the original pixel value.	1.00 DFNC Expert
Contrast Correction	contrastCorrection	Sets the contrast correction factor.	1.00 DFNC Expert
Brightness Correction	brightnessCorrection	Sets the brightness correction as a percentage.	1.00 DFNC Expert
LUT Mode	lutMode	Sets the enable state of the LUT module (Lookup Table).	1.00 DFNC Expert
<i>Off</i>	<i>Off</i>	<i>Disables the LUT.</i>	
<i>Active</i>	<i>Active</i>	<i>Enables the LUT.</i>	
LUT Index	LUTIndex	Selects the index (offset) of the coefficient to access in the selected LUT.	1.00 Guru
LUT Value	LUTValue	Returns the value at specified LUT index entry of the LUT selected by the LUT Selector feature.	1.00 Guru
LUT Value All	LUTValueAll	Accesses all the LUT coefficients in a single access without using individual LUT indices. This feature accesses the LUT values in the currently active LUT table set by the LUT Current Active Set feature.	1.00 Guru
Balance White Auto	BalanceWhiteAuto	Controls the mode for automatic white balancing between the color channels. The white balancing ratios are automatically adjusted.	1.00 Expert
<i>Off</i>	<i>Off</i>	<i>White balancing is user controlled using BalanceRatioSelector and BalanceRatio.</i>	
<i>Continuous</i>	<i>Continuous</i>	<i>White balancing is constantly adjusted by the device.</i>	
Balance Ratio Selector	BalanceRatioSelector	Selects which color gain is controlled with the BalanceRatio feature.	1.00 Expert
<i>Red</i>	<i>Red</i>	<i>RED gain is controlled by Balance Ratio.</i>	
<i>Green</i>	<i>Green</i>	<i>GREEN gain is controlled by Balance Ratio.</i>	
<i>Blue</i>	<i>Blue</i>	<i>BLUE gain is controlled by Balance Ratio.</i>	
Balance Ratio	BalanceRatio	Sets the digital gain of the selected color component (BalanceRatioSelector).	1.00 Expert

5.6 Image Format Control Category

The LT Series Image Format control has parameters used to configure camera pixel format, image cropping, decimation and others. Parameters in gray are read only, either always or due to another parameter being disabled. Parameters in black are user set.

Features listed in the description table but tagged as *Invisible* are usually for third party software usage—not typically needed by end user applications. Also important, Teledyne LUMENERA cameras are available in a number of models implementing different sensors and image resolutions which may not support the full feature set defined in this category.

Category	Parameter	Value
Camera Information	Sensor Width	2064
Sensor Control	Sensor Height	1544
I/O Control	Width	2064
<input checked="" type="checkbox"/> Advanced Processing	Height	1544
Color Processing	Decimation Horizontal	1
Image Format Control	Decimation Vertical	1
Acquisition Control	Offset X	0
<input checked="" type="checkbox"/> Event Control	Offset Y	0
Transport Layer Control	Pixel Format	BayerRG8
Teledyne Lumenera Control	Horizontal Flip	False
File Access Control	Vertical Flip	False
USB3 Vision Host Controls	<< Less	

5.6.1 Image Format Control Feature Description

The following table describes the features and values found in the category, as well as the device version and visibility level (beginner, expert, guru, invisible). The device version represents a camera software functional level (different from the firmware revision number) and may differ for each camera sensor. A major device version release is shown in green. The last column also indicates whether the feature is a member of the DALSA Features Naming Convention (DFNC) or the GenICam Standard Features Naming Convention (SFNC, tag not shown).

Display Name	Feature & Values	Description	Device Version & View
Sensor Width	SensorWidth	Effective width of the sensor in pixels.	1.00 Expert
Sensor Height	SensorHeight	Effective height of the sensor in pixels.	1.00 Expert
<u>Width</u>	Width	Width of the Image provided by the device (in pixels).	1.00 Beginner

Display Name	Feature & Values	Description	Device Version & View	
<u>Height</u>	Height	Height of the Image provided by the device (in lines).	1.00 Beginner	
Binning Horizontal	BinningHorizontal	Number of horizontal pixels to combine together. This reduces the horizontal resolution of the image.	1.00 Beginner	
Binning Vertical	BinningVertical	Number of vertical pixels to combine together. This reduces the vertical resolution of the image.	1.00 Beginner	
Decimation Horizontal	DecimationHorizontal	Horizontal sub-sampling of the image. This reduces the horizontal resolution (width) of the image by the specified horizontal decimation factor.	1.00 Beginner	
Decimation Vertical	DecimationVertical	Vertical sub-sampling of the image. This reduces the vertical resolution (height) of the image by the specified vertical decimation factor.	1.00 Beginner	
Offset X	OffsetX	Horizontal offset from the origin to the region of interest (in pixels).	1.00 Beginner	
Offset Y	OffsetY	Vertical offset from the origin to the region of interest (in pixels).	1.00 Beginner	
Pixel Format	PixelFormat	Format of the pixels provided by the device. It represents all the information provided by PixelSize, PixelColorFilter combined in a single feature.	1.00 Beginner	
<i>Mono8</i>	<i>Mono8</i>	<i>Monochrome 8-Bit</i>		
<i>Mono16</i>	<i>Mono16</i>	<i>Monochrome 16-Bit (12-bit image only in a 16-bit buffer)</i>		
<i>BayerGR8</i>	<i>BayerGR8</i>	<i>Bayer Green-Red 8-bit</i>		
<i>BayerGR16</i>	<i>BayerGR16</i>	<i>Bayer Green-Red 16-bit (12-bit image only in a 16-bit buffer)</i>		
<i>BayerGB8</i>	<i>BayerGB8</i>	<i>Bayer Green-Blue 8-bit</i>		
<i>BayerGB16</i>	<i>BayerGB16</i>	<i>Bayer Green-Blue 16-bit (12-bit image only in a 16-bit buffer)</i>		
<i>BayerBG8</i>	<i>BayerBG8</i>	<i>Bayer Blue-Green 8-bit</i>		
<i>BayerBG16</i>	<i>BayerBG16</i>	<i>Bayer Blue-Green 16-bit (12-bit image only in a 16-bit buffer)</i>		
<i>BayerRG8</i>	<i>BayerRG8</i>	<i>Bayer Red-Green 8-bit</i>		
<i>BayerRG16</i>	<i>BayerRG16</i>	<i>Bayer Red-Green 16-bit (12-bit image only in a 16-bit buffer)</i>		
<u>Horizontal Flip</u>	ReverseX	Horizontal image flip function.		1.00 Expert
<u>Vertical Flip</u>	ReverseY	Vertical image flip function.		1.00 Expert
Width Max	WidthMax	Maximum width of the image (in pixels). The dimension is calculated after horizontal binning, decimation or any other function changing the horizontal dimension of the image.	1.00 Invisible	
Height Max	HeightMax	Maximum height of the image (in pixels). This dimension is calculated after vertical binning, decimation or any other function changing the vertical dimension of the image.	1.00 Invisible	
Pixel Color Filter	PixelColorFilter	Indicates the type of color filter applied to the image.	1.00 Invisible	
<i>None</i>	<i>None</i>	<i>No color filter.</i>		

Display Name	Feature & Values	Description	Device Version & View
<i>BayerRG</i>	<i>BayerRG</i>	<i>Bayer Red Green filter.</i>	
<i>BayerGB</i>	<i>BayerGB</i>	<i>Bayer Green Blue filter.</i>	
<i>BayerGR</i>	<i>BayerGR</i>	<i>Bayer Green Red filter.</i>	
<i>BayerBG</i>	<i>BayerBG</i>	<i>Bayer Blue Green filter.</i>	

5.6.2 Width and Height Features for Partial Scan Control

Width and Height controls along with their respective Offset settings, allow the Lumenera to grab a region of interest (ROI) within the full image frame. Besides eliminating post acquisition image cropping done by software in the host computer, a windowed ROI grab reduces the transfer bandwidth required since less pixels are transmitted.

5.6.2.1 Vertical Cropping (Partial Scan)

The Height and Vertical Offset features, used for vertical cropping, reduce the number of video lines grabbed for a frame. By not scanning the full height of the sensor, the maximum possible acquisition frame rate is proportionately increased, up to the Lt Camera maximum.

The following figure is an example of a partial scan acquisition using both Height and Vertical Offset controls. The Vertical Offset feature defines at what line number from the sensor origin to acquire the image. The Height feature defines the number of lines to acquire (to a maximum of the remaining frame height). Note that only the partial scan image (ROI) is transmitted to the host computer.

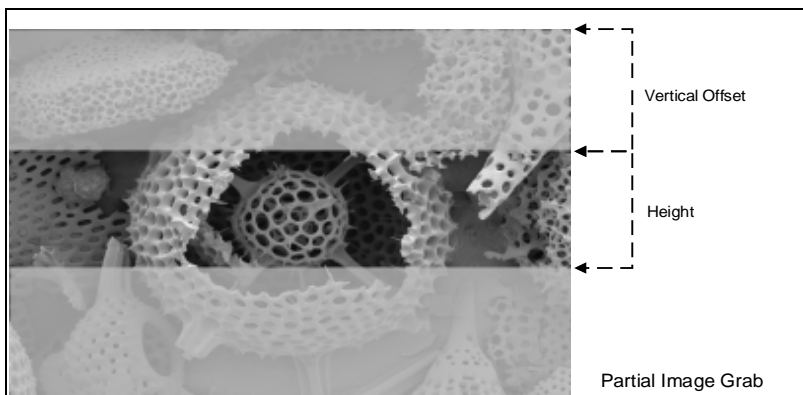

Note: In general, using short exposures at high frame rates will exceed the maximum bandwidth transfer speed, when the camera buffer memory is filled. The tables below (for different models) describe frame rate maximums written to internal memory that can be sustained during continuous acquisition. Increase the exposure time, decrease the frame rate, or acquire a limited number of frames, so as to not exceed the transfer bandwidth.

5.6.2.2 *Horizontal Cropping (Partial Scan)*

Lt Series cameras support cropping the acquisition horizontally by grabbing fewer pixels on each horizontal line. Horizontal offset defines the start of the acquired video line while horizontal width defines the number of pixels per line.

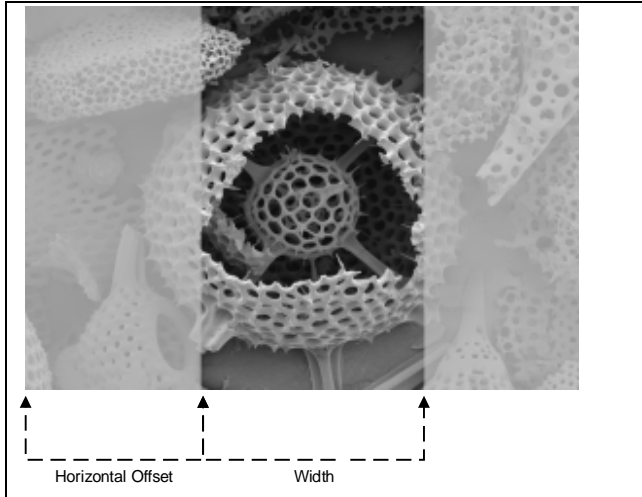

5.6.3 Horizontal and Vertical Flip

The Image Flip features activate image acquisition with horizontal and/or vertical inversion.

- Support of one or both of these functions is camera model specific since it is a function of sensor data readout, not post sensor processing.
- When image flip is supported directly at the sensor, activation of the flip function does not reduce the maximum frame rate possible from that model.
- The horizontal and/or vertical image flip functions acquire images as expected.

Acquisition Flip Features



Horizontal Flip (Mirror)

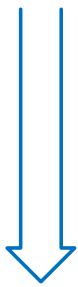

Vertical Flip

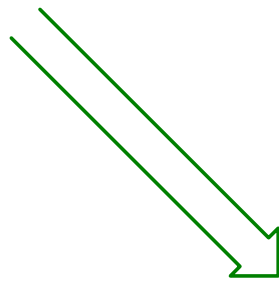
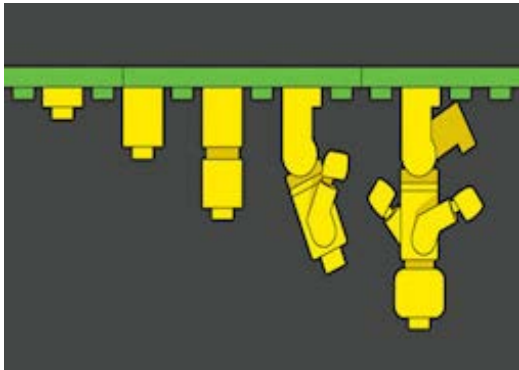

Both Horizontal & Vertical Flip

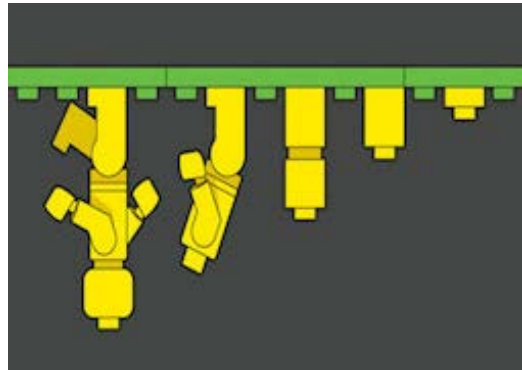

5.7 Acquisition Control Category

This feature group includes controls for acquisition management. Parameters in gray are read only, either always or due to other feature settings. Parameters in black are user set.

Features listed in the description table that are tagged as *Invisible* are usually for third party software usage—not typically needed by end user applications.

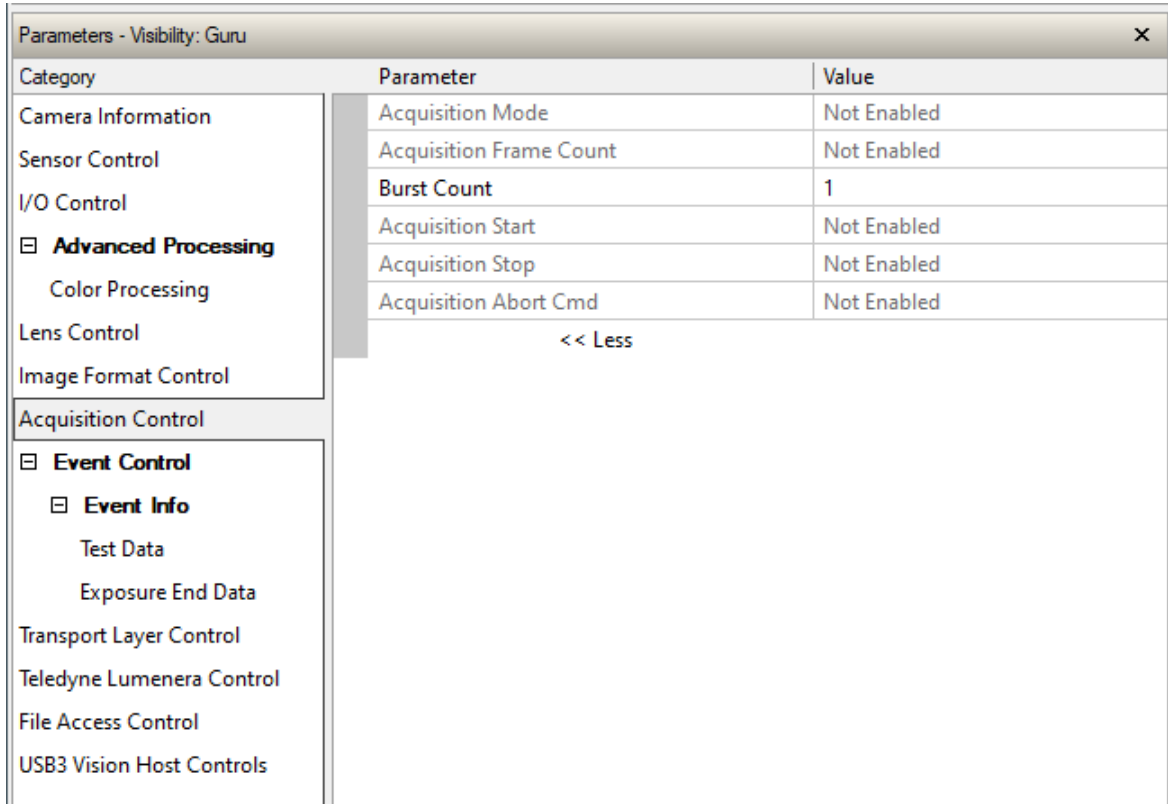

5.7.1 Acquisition Control Feature Descriptions

The following table describes the features and values found in the category, as well as the device version and visibility level (beginner, expert, guru, invisible). The device version represents a camera software functional level (different from the firmware revision number) and may differ for each camera sensor. A major device version release is shown in green. The last column also indicates whether the feature is a member of the DALSA Features Naming Convention (DFNC) or the GenICam Standard Features Naming Convention (SFNC, tag not shown).

Display Name	Feature & Values	Description	Device Version & View
Acquisition Mode	AcquisitionMode	Sets the acquisition mode of the device. It defines mainly the number of frames to capture during an acquisition and the way the acquisition stops.	1.00 Beginner
<i>Continuous</i>	<i>Continuous</i>	<i>Frames are captured continuously until stopped with the AcquisitionStop command.</i>	

Display Name	Feature & Values	Description	Device Version & View
<i>Single Frame</i>	<i>SingleFrame</i>	<i>One frame is captured for each AcquisitionStart Command. An AcquisitionStop occurs at the end of the Active Frame.</i>	
<i>Multi-Frame</i>	<i>MultiFrame</i>	<i>A sequence of frames is captured for each AcquisitionStart Command. The number of frames is specified by AcquisitionFrameCount feature. An AcquisitionStop occurs at the end of the Active Frame(s).</i>	
Acquisition Frame Count	AcquisitionFrameCount	Number of frames to be acquired in MultiFrame acquisition mode.	1.00 Beginner
Burst Count	AcquisitionBurstFrameCount	Number of consecutive snapshots to acquire on cameras that support fast multiple snapshots.	1.00 Guru
Acquisition Start	AcquisitionStart	Starts the Acquisition of the device. The number of frames captured is specified by AcquisitionMode.	1.00 Beginner
Acquisition Stop	AcquisitionStop	Stops the Acquisition of the device at the end of the current Frame.	1.00 Beginner
Acquisition Abort CMD	AcquisitionAbort	Aborts the acquisition immediately. This will end the capture without completing the current frame or aborts waiting on a trigger. If no acquisition is in progress, the command is ignored.	1.00 Beginner
Device Registers Streaming Start	DeviceRegistersStreamingStart	Announces the start of registers streaming without immediate checking for consistency.	1.00 Invisible
Device Registers Streaming End	DeviceRegistersStreamingEnd	Announces end of registers streaming and performs validation for registers consistency before activating them.	1.00 Invisible
Registers Check	DeviceRegistersCheck	Performs an explicit register set validation for consistency.	1.00 Invisible
Registers Valid	DeviceRegistersValid	States if the current register set is valid and consistent.	1.00 Invisible

5.8 Event Control Category

This feature group includes controls for event management. Parameters in gray are read only, either always or due to other feature settings. Parameters in black are user set.

Features listed in the description table that are tagged as *Invisible* are usually for third party software usage—not typically needed by end user applications.

Category	Parameter	Value
Camera Information	Timestamp Latch Value (in ns)	0
Sensor Control	Timestamp Latch	Press...
I/O Control	Timestamp Increment	320
Advanced Processing	Event Selector	End of Exposure
Color Processing	Event Notification	Off
Lens Control	<< Less	
Image Format Control		
Acquisition Control		
Event Control		
Event Info		
Test Data		
Exposure End Data		
Transport Layer Control		
Teledyne Lumenera Control		
File Access Control		
USB3 Vision Host Controls		

Category	Parameter	Value
Event Control	Test Event ID	20479
Event Info	<< Less	
Test Data		
Exposure End Data		

Category	Parameter	Value
Event Control	Exposure End Event ID	40006
Event Info	<< Less	
Test Data		
Exposure End Data		

5.8.1 Event Control Feature Descriptions

The following table describes the features and values found in the category, as well as the device version and visibility level (beginner, expert, guru, invisible). The device version represents a camera software functional level (different from the firmware revision number) and may differ for each camera sensor. A major device version release is shown in **green**. The last column also indicates whether the feature is a member of the DALSA Features Naming Convention (DFNC) or the GenICam Standard Features Naming Convention (SFNC, tag not shown).

Display Name	Feature & Values	Description	Device Version & View
Timestamp Latch Value	TimestampLatchValue	Returns the latched value of the timestamp.	1.00 Expert
Timestamp Latch	TimestampLatch	Latches the current Timestamp in the TimestampValue feature.	1.00 Expert
Timestamp Increment	timestampIncrement	Timestamp Increment	1.00 DFNC Expert
Event Selector	EventSelector	Select the Event to enable/disable with the EventNotification feature.	1.00 Expert
<i>End of Exposure</i>	<i>ExposureEnd</i>	<i>Event sent on control channel on end of exposure.</i>	
Event Notification	EventNotification	Enable Events for the event type selected by the EventSelector feature.	1.00 Expert
<i>Off</i>	<i>Off</i>	<i>The selected event is disabled.</i>	
<i>On</i>	<i>On</i>	<i>The selected event will generate a software event.</i>	
Test Event ID	EventTest	Represents the event ID to identify the EventTest software Event.	1.00 Guru
Test Data	EventTestData	Data of the U3V test event	1.00 Guru
Test Event Timestamp	EventTestTimestamp	Timestamp of the Test event.	1.00 Guru
Exposure End Event ID	EventExposureEnd	Represents the event ID to identify the EventExposureEnd software Event.	1.00 Guru
Exposure End Data	EventExposureEndData	Data of the exposure end event	1.00 Guru
Exposure End Event Timestamp	EventExposureEndTimestamp	Timestamp of the EventExposureEnd event.	1.00 Guru

5.9 Transport Layer Control Category

The Transport Layer control, as shown by a camera software tool, has parameters used to configure features related to USB3 Vision specification. Parameters in gray are read only, either always or due to another parameter being disabled. Parameters in black are user set or programmable via an imaging application.

Features listed in the description table but tagged as *Invisible* are usually for third party software usage—not typically needed by end user applications.

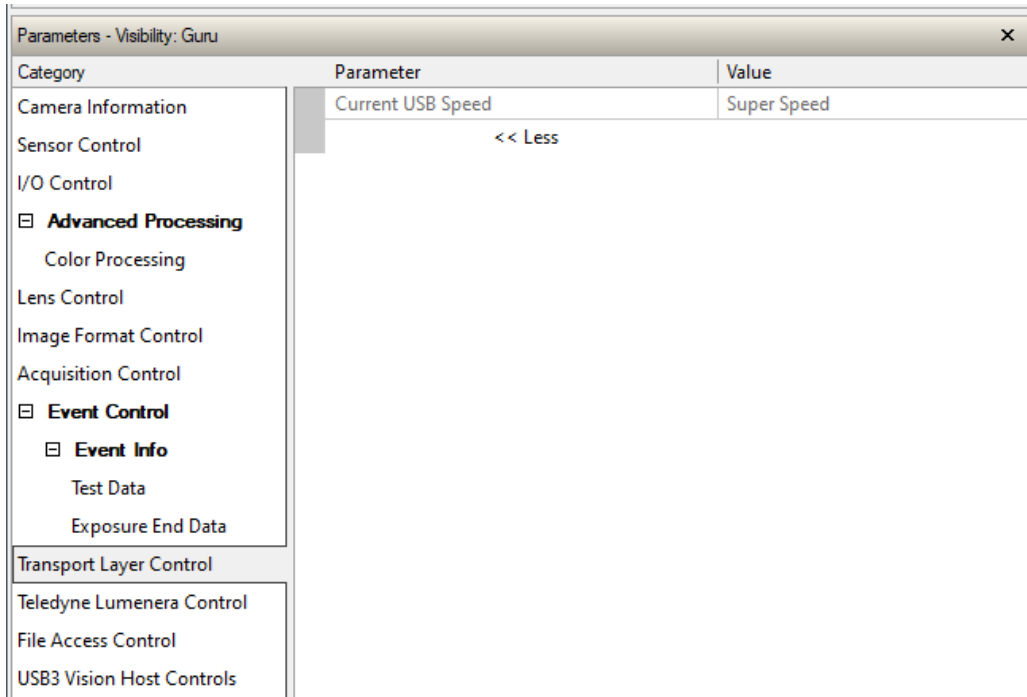

5.9.1 Transport Layer Feature Descriptions

The following table describes the features and values found in the category, as well as the device version and visibility level (beginner, expert, guru, invisible). The device version represents a camera software functional level (different from the firmware revision number) and may differ for each camera sensor. A major device version release is shown in green. The last column also indicates whether the feature is a member of the DALSA Features Naming Convention (DFNC) or the GenICam Standard Features Naming Convention (SFNC, tag not shown).

Display Name	Feature & Values	Description	Device Version & View
Current USB Speed	U3VCurrentSpeed	Current Speed of the USB link.	1.00 Beginner
<i>Low Speed</i>	<i>LowSpeed</i>		
<i>Full Speed</i>	<i>FullSpeed</i>		
<i>High Speed</i>	<i>HighSpeed</i>		
<i>Super Speed</i>	<i>SuperSpeed</i>		
	PayloadSize	Provides the number of bytes transferred for each image or chunk on the stream channel.	1.00 Invisible

5.10 Teledyne Lumenera Control Category

Features listed in the description table but tagged as *Invisible* are usually for third party software usage—not typically needed by end user applications.

Warning: Setting the **cameraBootSequence** feature to *LuCam* and resetting the camera will disable access to the camera via USB3 Vision. The LuCam mode protocol is required for use of the Lumenera LuCam API – not Sopera LT API. See **Switching a Lumenera camera from LuCam mode to USB3 Vision mode** and **Switching a Lumenera camera from USB3 Vision mode to LuCam** mode in troubleshooting for information and methods required to switch a camera mode.

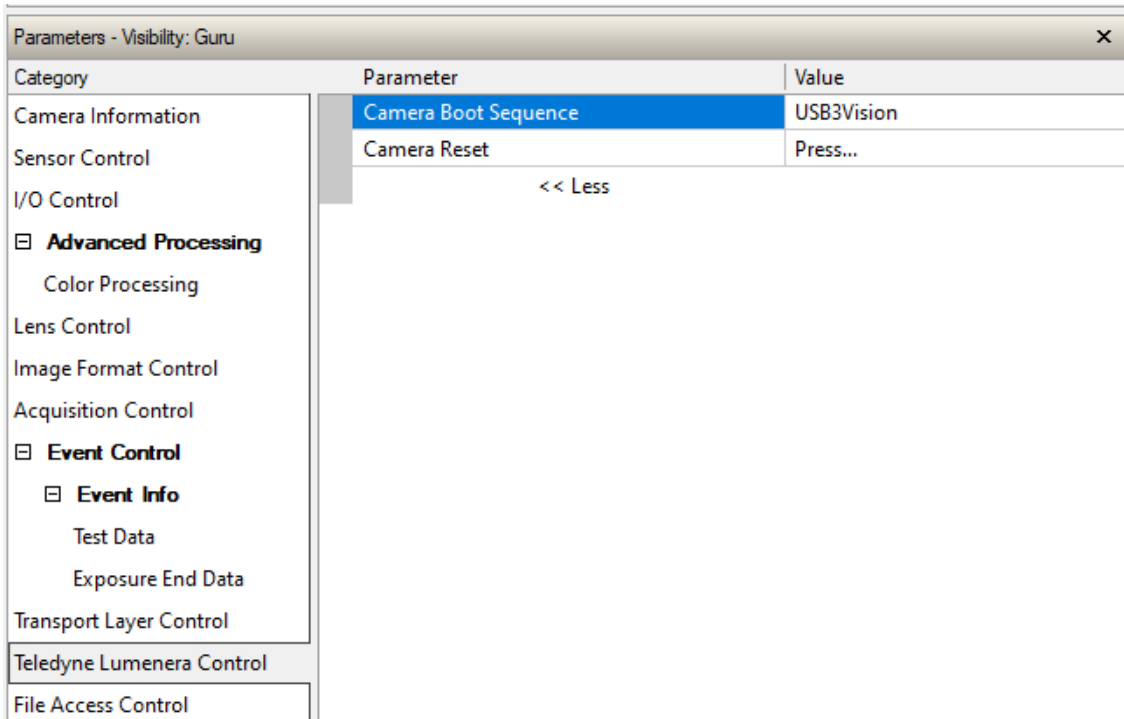

5.10.1 Teledyne Lumenera Control Feature Descriptions

The following table describes the features and values found in the category, as well as the device version and visibility level (beginner, expert, guru, invisible). The device version represents a camera software functional level (different from the firmware revision number) and may differ for each camera sensor. A major device version release is shown in green. The last column also indicates whether the feature is a member of the DALSA Features Naming Convention (DFNC) or the GenICam Standard Features Naming Convention (SFNC, tag not shown).

Display Name	Feature & Values	Description	Device Version & View
Camera Boot Sequence	cameraBootSequence	Boot camera as USB3 Vision or LuCam.	Guru
<i>LuCam</i>	<i>LuCam</i>	<i>LuCam protocol (applicable when using the Teledyne Lucam API software)</i>	
<i>USB3Vision</i>	<i>USB3Vision</i>	<i>USB3Vision protocol (compatible with Genicam and USB3 Vision software API)</i>	
Camera Reset	CameraReset	Resets the camera features to its power-on default state but does not do a hardware camera reset.	Beginner

5.11 File Access Control Category

File Access control in CamExpert allows the user to quickly upload or download camera firmware and other data.

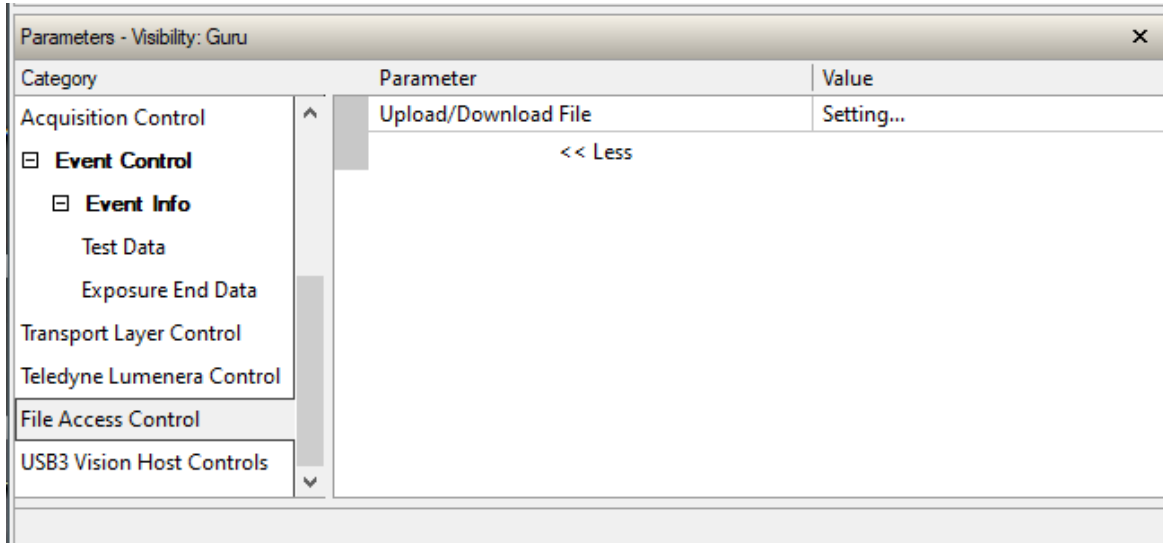

5.11.1 File Access Control Feature Descriptions

The following table describes the features and values found in the category, as well as the device version and visibility level (beginner, expert, guru, invisible). The device version represents a camera software functional level (different from the firmware revision number) and may differ for each camera sensor. A major device version release is shown in green. The last column also indicates whether the feature is a member of the DALSA Features Naming Convention (DFNC) or the GenICam Standard Features Naming Convention (SFNC, tag not shown).

Display Name	Feature & Values	Description	Device Version & View
File Selector	FileSelector	Selects the file to access. The file types which are accessible are device-dependent.	1.00 Guru
<i>Firmware</i>	<i>Firmware1</i>	<i>Upload new firmware to the camera, which will execute on the next camera reboot cycle. Select the DeviceReset feature after the upload completes.</i>	
<i>Image</i>	<i>Image</i>	<i>Sample image taken with this unit.</i>	
File Operation Selector	FileOperationSelector	Selects the target operation for the selected file in the device. This operation is executed when the File Operation Execute feature is called.	1.00 Guru
<i>Open</i>	<i>Open</i>	<i>Select the Open operation – executed by FileOperationExecute.</i>	
<i>Close</i>	<i>Close</i>	<i>Select the Close operation – executed by FileOperationExecute</i>	
<i>Read</i>	<i>Read</i>	<i>Select the Read operation – executed by FileOperationExecute.</i>	
<i>Write</i>	<i>Write</i>	<i>Select the Write operation – executed by FileOperationExecute.</i>	

Display Name	Feature & Values	Description	Device Version & View
<i>Delete</i>	<i>Delete</i>	<i>Select the Delete operation – executed by FileOperationExecute.</i>	
File Operation Execute	FileOperationExecute	Executes the operation selected by File Operation Selector on the selected file.	1.00 Guru
File Open Mode	FileOpenMode	Selects the access mode used to open a file on the device.	1.00 Guru
<i>Read</i>	<i>Read</i>	<i>Select read-only open mode</i>	
<i>Write</i>	<i>Write</i>	<i>Select write-only open mode</i>	
File Access Offset	FileAccessOffset	Controls the mapping offset between the device file storage and the file access buffer.	1.00 Guru
File Access Length	FileAccessLength	Controls the mapping length between the device file storage and the file access buffer.	1.00 Guru
File Access Buffer	FileAccessBuffer	Defines the intermediate access buffer that allows the exchange of data between the device file storage and the application.	1.00 Guru
File Operation Status	FileOperationStatus	Displays the file operation execution status.	1.00 Guru
<i>Success</i>	<i>Success</i>	<i>The last file operation has completed successfully.</i>	
<i>Failure</i>	<i>Failure</i>	<i>The last file operation has completed unsuccessfully for an unknown reason.</i>	
<i>File Unavailable</i>	<i>FileUnavailable</i>	<i>The last file operation has completed unsuccessfully because the file is currently unavailable.</i>	
<i>File Invalid</i>	<i>FileInvalid</i>	<i>The last file operation has completed unsuccessfully because the selected file is not present in this camera model.</i>	
File Operation Result	FileOperationResult	Displays the file operation result. For Read or Write operations, the number of successfully read/written bytes is returned.	1.00 Guru
File Size	FileSize	Represents the size of the selected file in bytes.	1.00 Guru

5.11.2 File Access via the CamExpert Tool (Quick Camera Firmware Upgrade)

- In the **File Access Control** category, click **Setting** to open the File Access Control dialog.

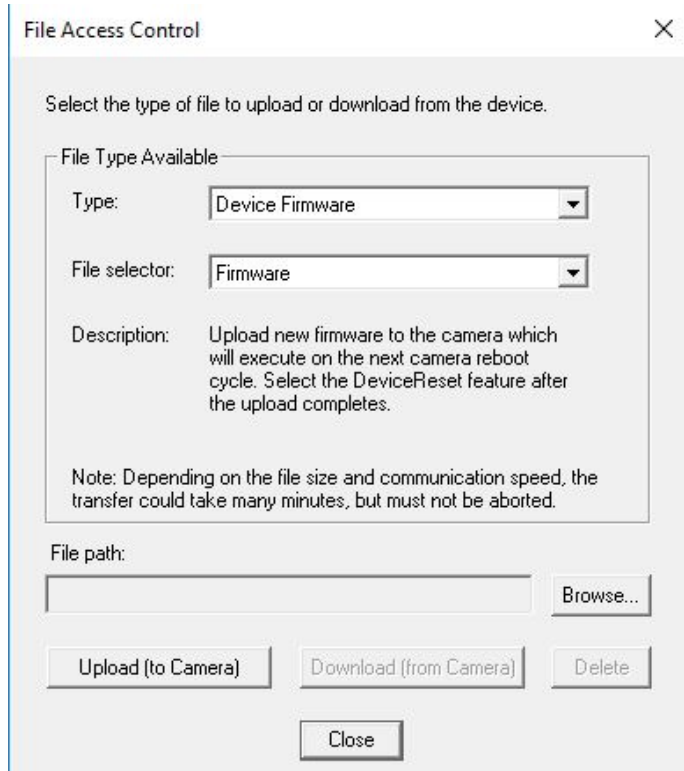

Figure 1: File Access Menu

- From the **Type** list, choose the type of file to upload to the camera.
- From the **File selector** list, choose *Firmware*.
- Click **Browse** to open Windows Explorer.
- Select the .cbf firmware file to upload.
- Click **Upload (to Camera)** to execute the file transfer to the camera.

5.12 USB3 Vision Host Controls Category

The USB3 Vision Host Controls group parameters are used to configure the host computer system features for camera communication management. None of the parameters are stored in the camera.

The features allow optimizing the configuration for maximum bandwidth.

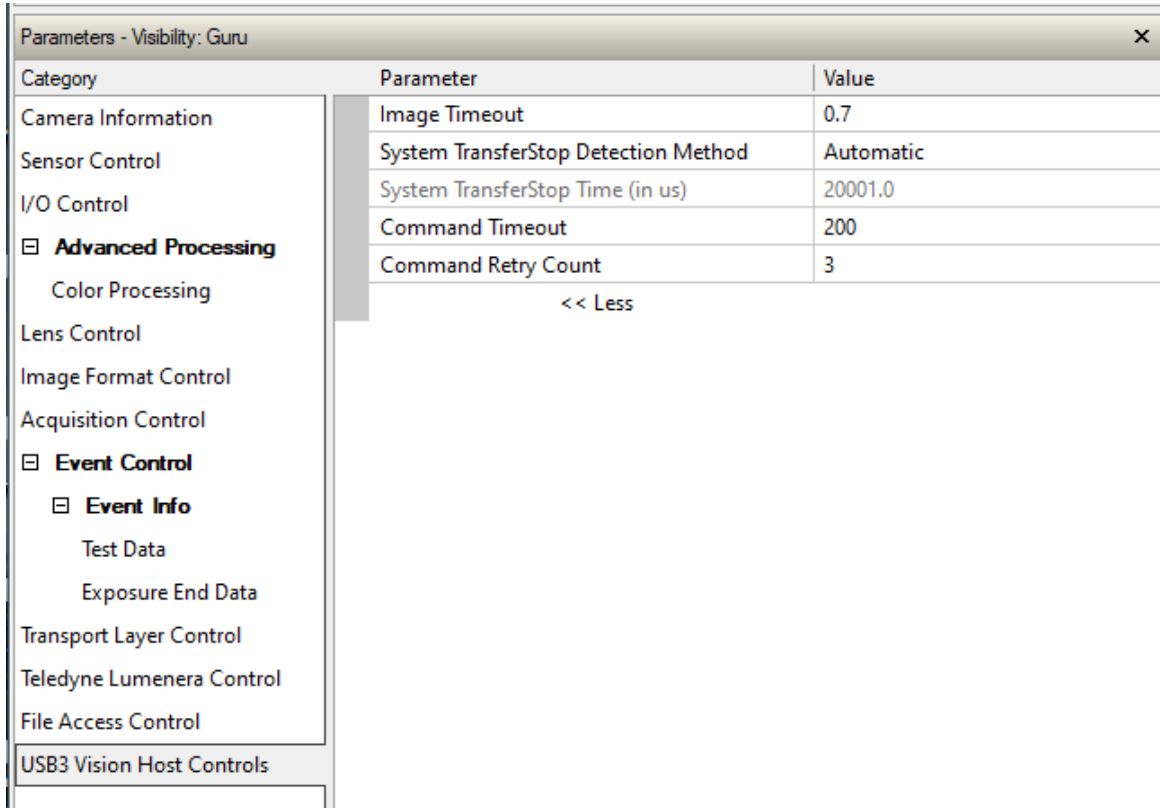

Category	Parameter	Value
Camera Information	Image Timeout	0.7
Sensor Control	System TransferStop Detection Method	Automatic
I/O Control	System TransferStop Time (in us)	20001.0
<input checked="" type="checkbox"/> Advanced Processing	Command Timeout	200
Color Processing	Command Retry Count	3
Lens Control	<< Less	
Image Format Control		
Acquisition Control		
<input checked="" type="checkbox"/> Event Control		
<input checked="" type="checkbox"/> Event Info		
Test Data		
Exposure End Data		
Transport Layer Control		
Teledyne Lumenera Control		
File Access Control		
USB3 Vision Host Controls		

6 Technical Specifications

6.1 Identification and Mechanical Notes

Identification Label

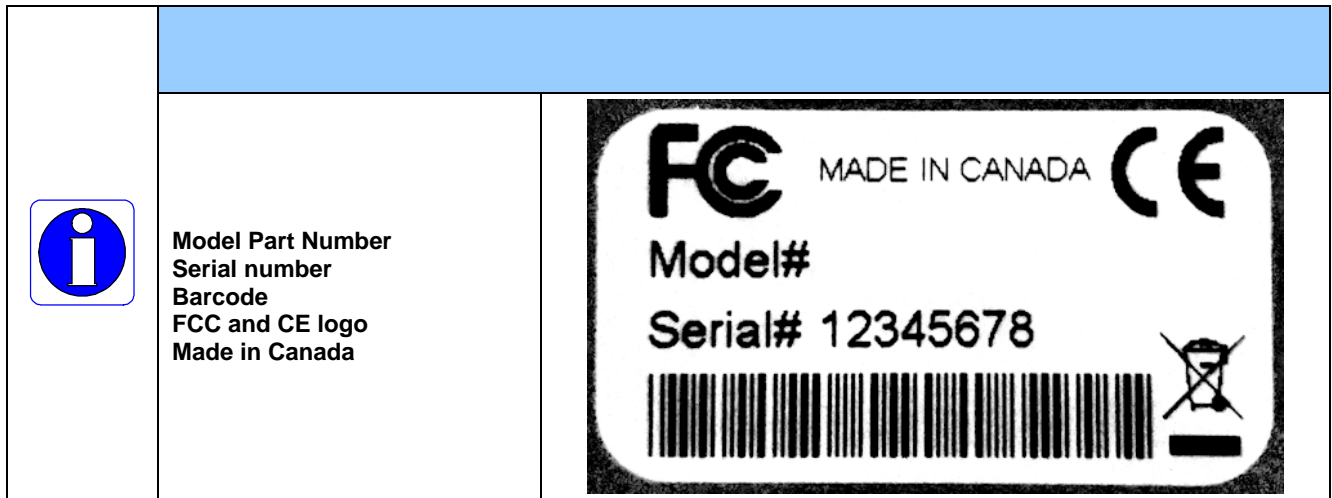

Additional Mechanical Notes

	<p>Lt camera series supports a screw lock USB3 cable as described in Ruggedized Cable Accessories Ruggedized Cable Accessories.</p>
---	---

6.2 Mechanical Specifications

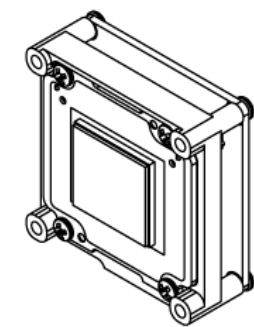
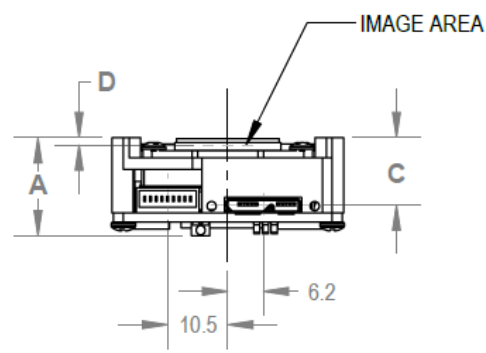
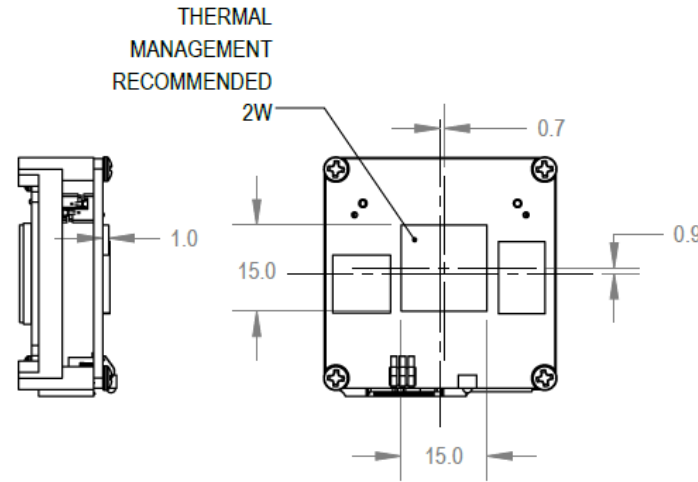
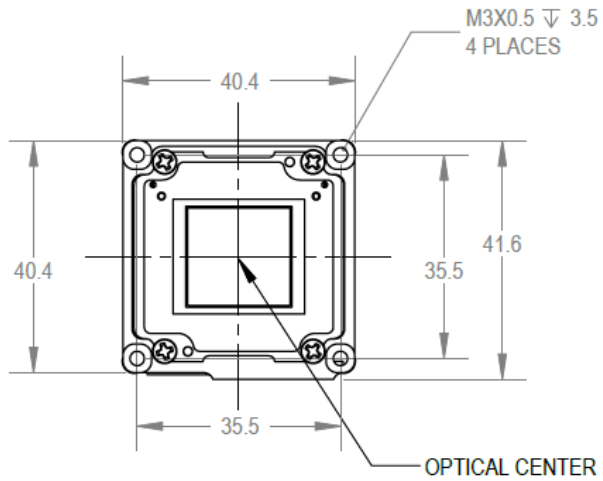

MODELS	DIMENSION		
	A	C	D
Lt-1610B Lt-1630B Lt-1950B Lt-1980B Lt-2020B Lt-2420B Lt-3200B Lt-4020B Lt-4030B Lt-5500B	17.1	11.9	1.3
Lt-1900B	14.1	8.9	1.6
Lt-3840B	14.1	8.9	1.4

6.3 Temperature Management

Lt Series cameras are designed to optimally transfer internal component heat to an outer metallic structure. If the camera is free standing (i.e. not mounted) it will be very warm to the touch.

Basic heat management is achieved by mounting the camera onto a metal structure via its mounting screws.

6.4 Sensor Alignment Specification

The following figure specifies sensor alignment for the Lt Series where all specifications define the absolute maximum tolerance allowed for production cameras. Dimensions "x, y, z", are in microns and referenced to the mechanical body or the optical focal plane (for the z-axis dimension). Theta specifies the sensor rotation relative to the sensor's center and mechanical body.

X variance	0 mm nominal	+/- 0.97 mm	<p>Sensor Alignment Reference</p> <p>(+/-) Y variance</p> <p>(+/-) theta variance</p> <p>Z variance not shown</p> <p>(+/-) X variance</p>
Y variance	0 mm nominal	+/- 0.97 mm	
Z lens mount to sensor	17.52 mm nominal	+ .13 / -.18 mm	
Theta variance		+/- 2 degree	

6.5 Connectors

6.5.1 Connector Locations for Series LT-xx1x-xxxx

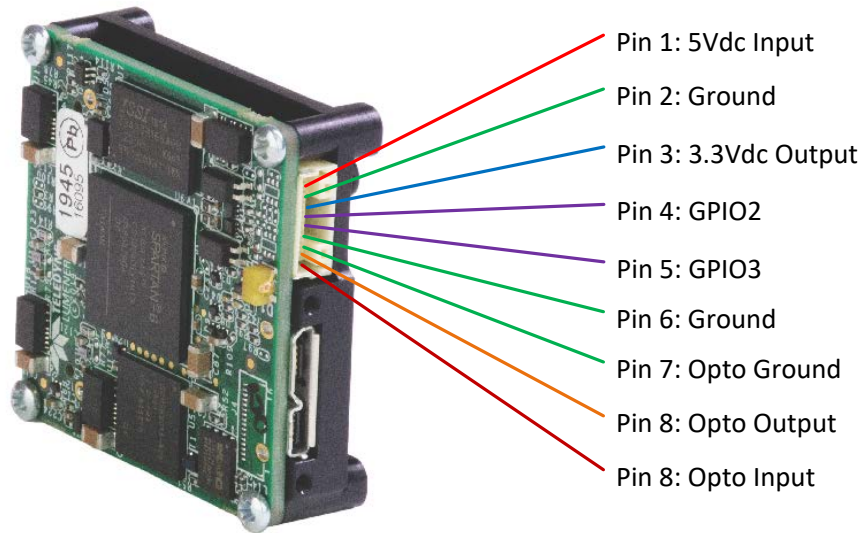

I/O Connector Pin Numbers as Viewed by User

6.5.1.1 I/O Connector Pinout Details

Mating connector JST NSHR-09V-S is available at Digi-Key (ref: 455-2785-ND)

Pin Number	Function	Description
1	V-External	External power input terminal (5 V +/- 7.5%, 2 A)
2	GND	External power ground reference terminal
3	3.3 Vdc output	Output supplying a maximum of 150 mA
4	GPIO2	Bi-directional general purpose I/O #2 terminal
5	GPIO3	Bi-directional general purpose I/O #3 terminal
6	GND	External power ground reference terminal
7	Opto GND	External ground reference for Opto signal
8	Opto Output	Optically isolated output
9	Opto Input	Optically isolated input

6.5.2 Bi-directional I/O DC Specifications

GPO Operating Characteristics (GPIO2 & GPIO3 as outputs)		
LOW value: 0.0 to 0.6 V	HIGH value: 2.65 to 3.3 V	Typical output current: 24 mA
GPI Operating Characteristics (GPIO2 & GPIO3 as inputs)		
LOW input voltages: 0.0 to 0.8 V	HIGH input voltages: 2.0 to 5.0 V	

6.5.3 Optically-Isolated Input Specifications

The optically-isolated input pins are designed to operate from 3.3 V to 24 V at a typical current of 20 mA (maximum 50 mA). Greater input voltages are supported with use of an external voltage dropping resistor.

The following simplified circuit diagram shows a typical method to connect an external input:

- The external signal is applied to the Opto In input, and the Opto Ground is connected to ground. When the external signal goes positive relative to ground and current flows through the input pins, the camera receives an active high trigger signal.
- The opto-isolated internal current limiting resistor is 800 Ω .

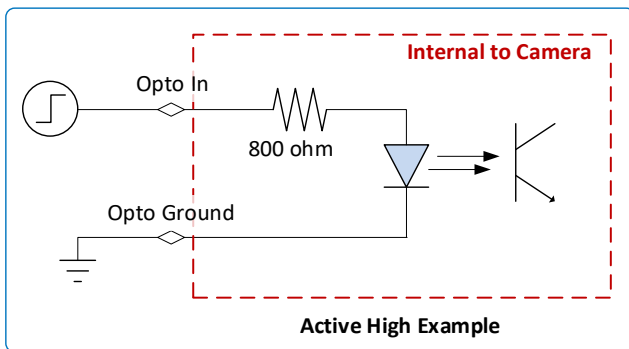

6.5.4 Optically-Isolated Output Specifications

The optically-isolated output requires an external resistor and biasing current. The current flow through the signal output transistor should nominally be 20 mA and must not exceed 50 mA.

The following simplified circuit diagram shows a method for connecting the output to an external circuit. The example uses a 5 V bias supply (output referenced to 5 V) and a 220 Ω series resistor.

- When using a 12 V bias supply (for Vcc) a 560 Ω resistor is suggested.
- The output signal swings between Vcc and ground.

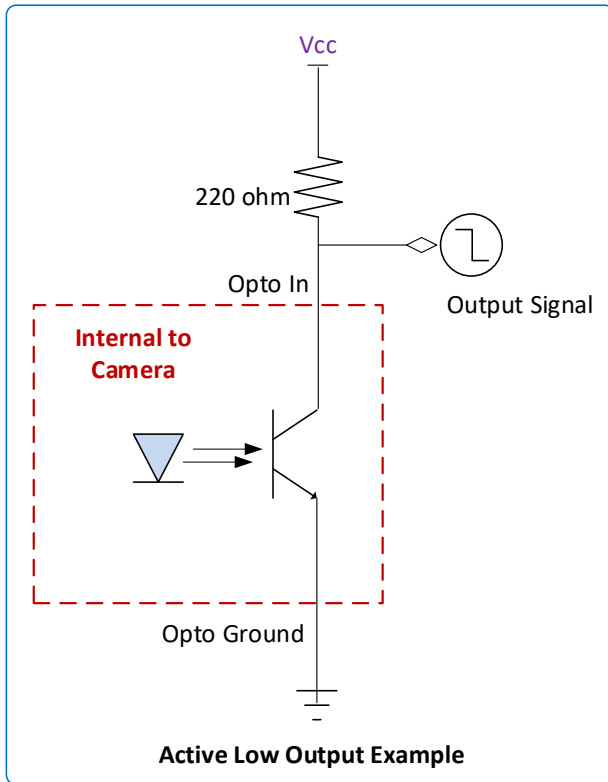

6.6 Computer Requirements for Lt Cameras

- A USB 3.0 equipped desktop, laptop or embedded computer will have the 5 volt power supply required by the Lt Series cameras.
- The computer requires the Windows 10 or Linux operating system.
- Teledyne DALSA Sopera LT development package.
- Alternatively refer to your USB3 Vision compliant SDK for computer requirements.

6.7 EC & FCC Declarations of Conformity



EC Declaration of Conformity

Products:

Lt-C1610, Lt-C1630, Lt-C1900, Lt-C1950, Lt-C1980, Lt-C2020, Lt-C2420, Lt-C3200, Lt-C3840, Lt-C4020, Lt-C4030, Lt-C5500, Lt-M1610, Lt-M1630, Lt-M1950, Lt-M1980, Lt-M2020, Lt-M2420, Lt-M3200, Lt-M3840, Lt-M4020, Lt-M4030, Lt-M5500

Directives: 2014/30/EU (Electromagnetic Compatibility Directive)
2011/65/EU (Restriction of Hazardous Substances Directive)

Standards to which conformity is declared:

EN 55032:2015/A11:2020 (Lt-C5500 and Lt-M5500 only)
EN 55032:2012/AC:2013
EN 55035:2017
EN 50581:2012

Manufacturer's Name and Address:

Teledyne Lumenera Corporation
7 Capella Court
Ottawa, Ontario
K2E 8A7
Canada

Type of Equipment: Digital Camera

This is to certify that the Teledyne Lumenera Cameras meet or exceed the standards for CE compliance per the Council Directives noted above. All equipment is assembled at Teledyne Lumenera Corporation.

Authorization Signature:



Doug Sanderson
VP Engineering

Jun 8, 2021

Date

7 Additional Reference Information

7.1 Choosing a Lens with the Correct Image Circle

Each Lt Series model requires a lens with an image circle specification to fully illuminate the sensor. The following section graphically shows the minimum lens image circle for each model family along with alternative lens types. Brief information on other lens parameters to consider follows those sections.

7.1.1 Lens Options for Lt-1900

- The following figure shows the lens image circles relative to this model.
- A 1/2.8" lens can be used with these models.

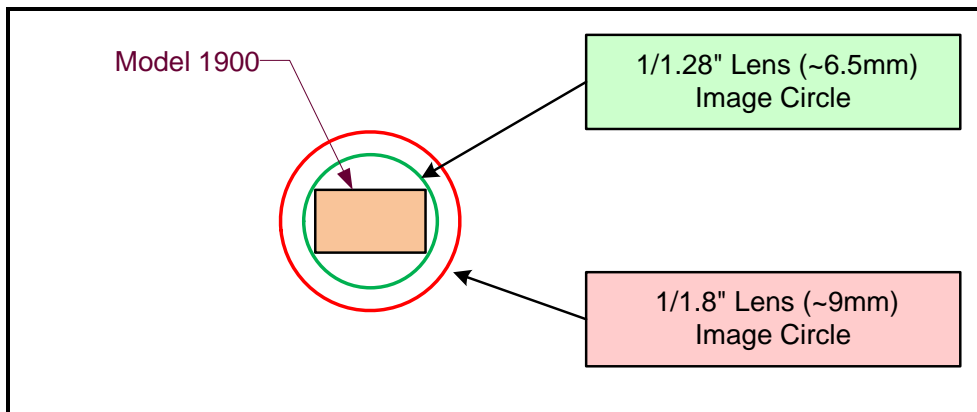

7.1.2 Lens Options for Lt-1950

- The following figure shows the lens image circles relative to this model, in color or monochrome versions.
- A 1/2.3" lens can be used with these models.

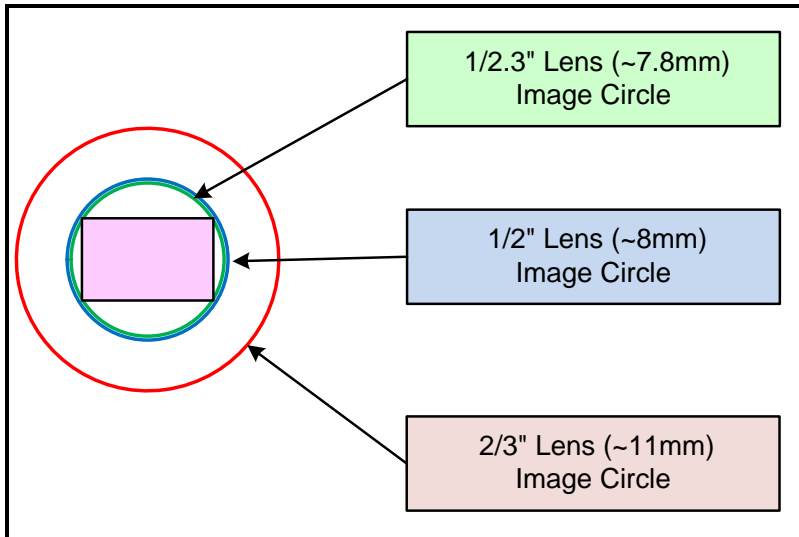

7.1.3 Lens Options for Lt-2020, Lt-3840

- The following figure shows the lens image circles relative to these models, in color or monochrome versions.
- A 1/1.8" lens can be used with these models.

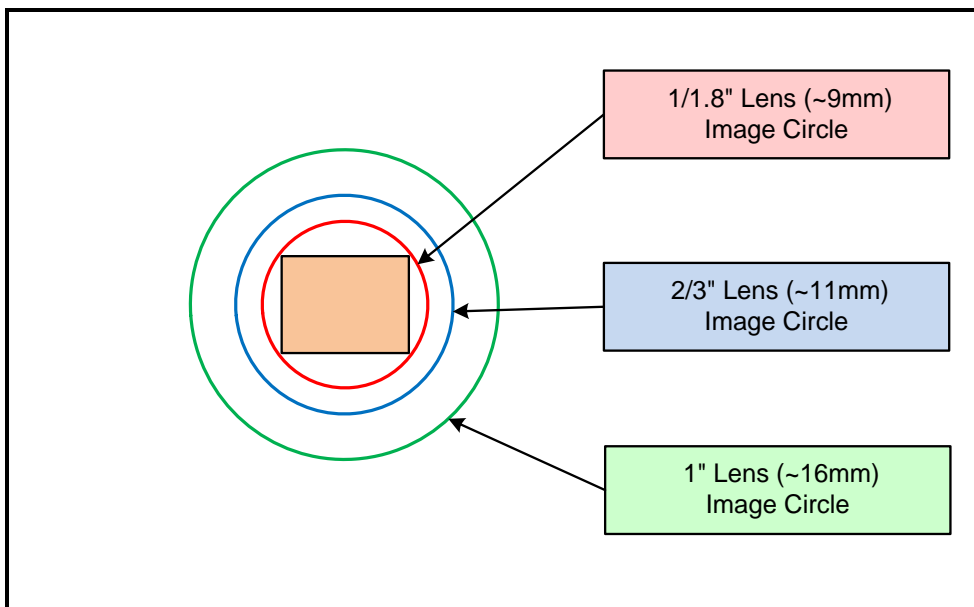

7.1.4 Lens Options for Lt-1980, Lt-2420

- The following figure shows the lens image circles relative to these models, in color or monochrome versions.
- A typical 2/3" lens will fully illuminate these sensors.

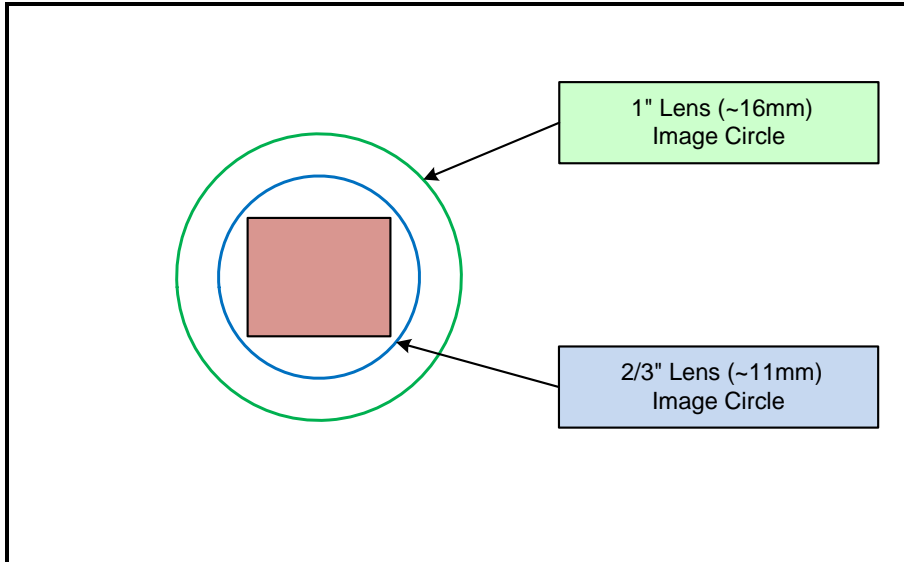

7.1.5 Lens Options for Lt-1630

- The following figure shows the lens image circles for this model, in color or monochrome versions.
- A 1/1.7" lens can be used with this model.

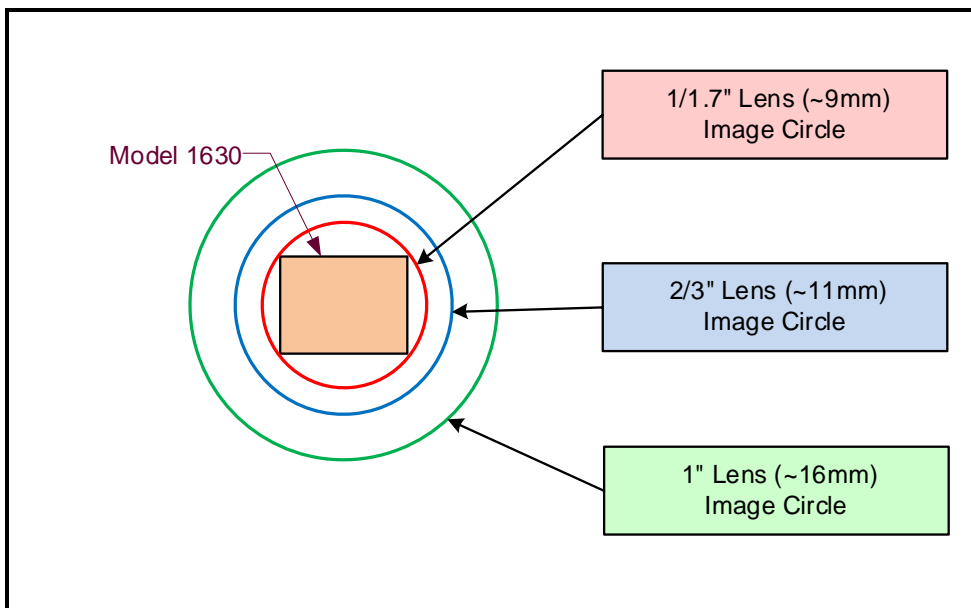

7.1.6 Lens Options for Lt-4030, Lt-5500

- The following figure shows the lens image circles relative to these models, in color or monochrome versions.
- A typical 1" lens will just illuminate these sensors while larger image circle lens will avoid any corner shading.

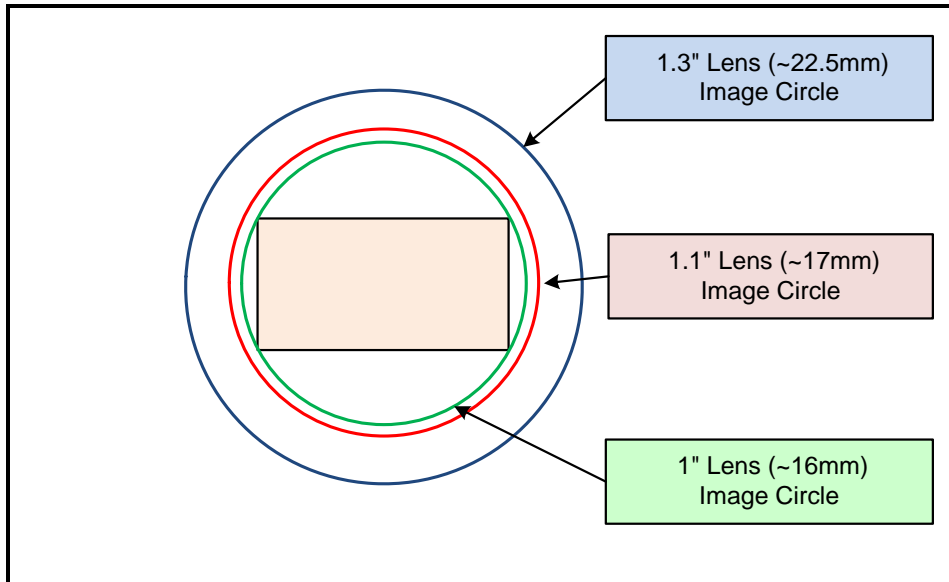

7.1.7 Lens Options for Lt-1610, Lt-3200, Lt-4020

- The following figure shows the lens image circles relative to these models, in color or monochrome versions.
- A typical 1.1" lens will illuminate these sensors.

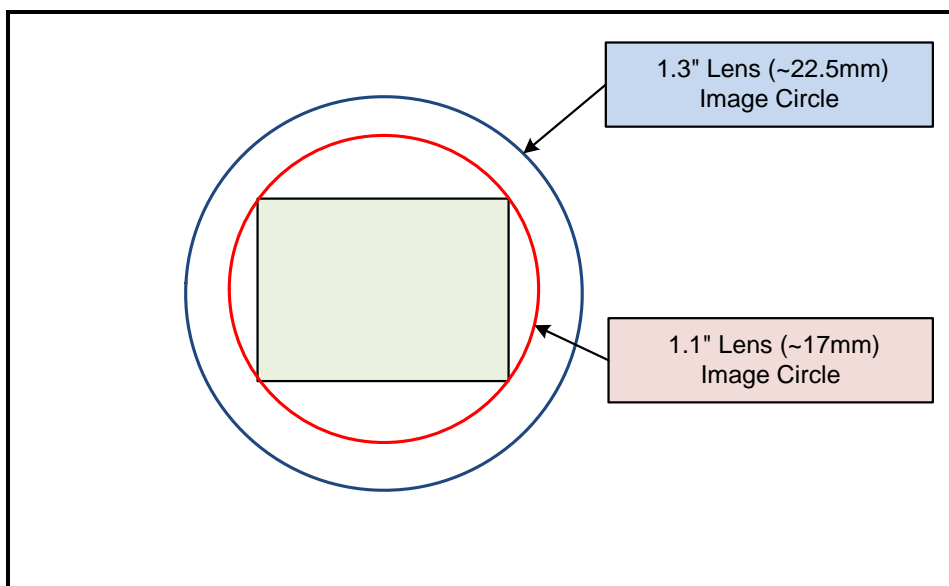

7.1.8 Additional Lens Parameters (application specific)

There are other lens parameters that are chosen to meet the needs of the vision application. These parameters are independent of the Lt Model (assuming that the Lens Mount and Lens Sensor Size parameters are correct, as previously covered in this section). A vision system integrator or lens specialist should be consulted when choosing lenses since there is a trade-off between the best lenses and cost. An abridged list of lens parameters follows – all of which need to be matched to the application.

- **Focal Length:** Defines the focus point of light from infinity. This parameter is related to the Lt Mount (C or CS mount).
- **Field of View:** A lens is designed to image objects at some limited distance range, at some positive or negative magnification. This defines the field of view.
- **F-Number (aperture):** The lens aperture defines the amount of light that can pass. Lenses may have fixed or variable apertures. Additionally, the lens aperture affects Depth of Field which defines the distance range which is in focus when the lens is focused at some specific distance.
- **Image Resolution and Distortion:** A general definition of image quality. A lens with poor resolution seems to never be in focus when used to image fine details.
- **Aberrations (defect, chromatic, spherical):** Aberrations are specific types of lens faults affecting resolution and distortion. Lens surface defects or glass faults distort all light or specific colors. Aberrations are typically more visible when imaging fine details.
- **Spatial Distortions:** Describes non-linear lens distortions across the field of view. Such distortion limits the accuracy of measurements made with that lens.

7.2 Optical Considerations

This section provides an overview to illumination, light sources, filters, lens modeling and lens magnification. Each of these components contributes to the successful design of an imaging solution.

7.2.1 Illumination

The amount and wavelengths of light required to capture useful images depend on the particular application. Factors include the nature, speed and spectral characteristics of objects being imaged, exposure times, light source characteristics, environmental and acquisition system specifics, and more. The Teledyne DALSA Web site provides an introduction to this potentially complicated issue along with many other application notes and guides on machine vision. Start with this Knowledge Center article: <http://www.teledynedalsa.com/en/learn/knowledge-center/machine-vision-101-an-introduction/>.

It is often more important to consider exposure than illumination. The total amount of energy (which is related to the total number of photons reaching the sensor) is more important than the rate at which it arrives. For example, $5 \mu\text{J}/\text{cm}^2$ can be achieved by exposing $5 \text{ mW}/\text{cm}^2$ for 1 ms just the same as exposing $5 \text{ W}/\text{cm}^2$ for 1 μs .

7.2.2 Light Sources

Keep these guidelines in mind when selecting and setting up light source:

- LED light sources are relatively inexpensive and provide a uniform field and longer life span compared to other light sources. However, they also require a camera with excellent sensitivity.
- Halogen light sources generally provide very little blue relative to infrared light (IR).
- Fiber-optic light distribution systems generally transmit very little blue relative to IR.
- Some light sources age such that over their life span they produce less light. This aging may not be uniform—a light source may produce progressively less light in some areas of the spectrum but not others.

7.3 Sensor Handling Instructions

This section reviews proper procedures for handling, cleaning, or storing the Lumenera Lt camera. Specifically, the Lumenera Lt sensor needs to be kept clean and away from static discharge to maintain design performance.

7.3.1 Electrostatic Discharge and the Sensor

Cameras sensors containing integrated electronics are susceptible to damage from electrostatic discharge (ESD).

Electrostatic charge introduced to the sensor window surface can induce charge buildup on the underside of the window that cannot be readily dissipated by the dry nitrogen gas in the sensor package cavity. With charge buildup, problems such as higher image lag or a highly non-uniform response may occur. The charge normally dissipates within 24 hours and the sensor returns to normal operation.



Important: Charge buildup will affect the camera's flat-field correction calibration. To avoid an erroneous calibration, ensure that you perform flat-field correction only after a charge buildup has dissipated over 24 hours.

7.3.2 Protecting Against Dust, Oil and Scratches

The sensor window is part of the optical path and should be handled like other optical components, with extreme care.

Dust can obscure pixels, producing dark patches on the sensor response. Dust is most visible when the illumination is collimated. The dark patches shift position as the angle of illumination changes. Dust is normally not visible when the sensor is positioned at the exit port of an integrating sphere, where the illumination is diffuse.

Dust can normally be removed by blowing the window surface using a compressed air blower, unless the dust particles are being held by an electrostatic charge, in which case either an ionized air blower or wet cleaning is necessary.

Oil is usually introduced during handling. Touching the surface of the window barehanded will leave oily residues. Using rubber finger cots and rubber gloves can prevent oil contamination. However, the friction between the rubber and the window may produce electrostatic charge that may damage the sensor.

Scratches can be caused by improper handling, cleaning or storage of the camera. When handling or storing the camera without a lens, always install the C-mount protective cap. Scratches diffract incident illumination. When exposed to uniform illumination, a sensor with a scratched window will normally have brighter pixels adjacent to darker pixels. The location of these pixels changes with the angle of illumination.

7.3.3 Cleaning the Sensor Window

Even with careful handling, the sensor window may need cleaning. The following steps describe various cleaning techniques to clean minor dust particles to accidental finger touches.

- Use compressed air to blow off loose particles. This step alone is usually sufficient to clean the sensor window. Avoid moving or shaking the compressed air container and use short bursts of air while moving the camera in the air stream. Agitating the container will cause condensation to form in the air stream. Long air bursts will chill the sensor window causing more condensation. Condensation, even when left to dry naturally, will deposit more particles on the sensor.
- When compressed air cannot clean the sensor, Teledyne Lumenera recommends using lint-free ESD-safe cloth wipers that do not contain particles that can scratch the window. The Anticon Gold 9"x 9" wiper made by Milliken is both ESD safe and suitable for class 100 environments. Another ESD acceptable wiper is the TX4025 from Texwipe.
- An alternative to ESD-safe cloth wipers is Transplex swabs that have desirable ESD properties. There are several varieties available from Texwipe. Do not use regular cotton swabs, since these can introduce static charge to the window surface.
- Wipe the window carefully and slowly when using these products.

7.4 Ruggedized Cable Accessories

Teledyne provides optional I/O cable assemblies for Lumenera Lt. Users wishing to build their I/O cabling by starting from available cable packages should consider these popular assemblies described below. Contact Sales for pricing and delivery.

Users also may order cable assembly quantities directly from Alysium-Tech or Components Express. In such cases use the manufacturer's part number shown on the cable assembly engineering drawing.

7.4.1 Cable Manufactures Contact Information

<p>For Information contact: (see their web site for worldwide offices)</p>	<p>Components Express, Inc. (CEI) 10330 Argonne Woods Drive, Suite 100 Woodridge, IL 60517-4995 Phone: 630-257-0605 / 800.578.6695 (outside Illinois) Fax: 630-257-0603 http://www.componentsexpress.com/</p>
---	---

<p>For Information contact: (see their web site for worldwide offices)</p>	<p>Alysium-Tech 101 Montgomery Street, Suite 2050 San Francisco, CA 94104 Phone: 415 248 7807 Fax: 415 248 7800 https://www.alysium.com/</p>
---	---

7.4.2 Long Passive Cables and Optical Cables

Contact Alysium-Tech for information on these cabling choices.

7.4.3 USB3 Long Distance Active Cables

CEI's USB3 BitMaxx cables offer Plug & Play active cable solutions for USB Vision. Please visit the web site for Components Express to review their cable options.

https://www.componentsexpress.com/Bit_MAXX-long-distance-usb3-cables

cei COMPONENTS EXPRESS, INC.
INDUSTRY LEADING PERFORMANCE

Machine Vision
Long distance USB3 Cables

5M
Standard USB3 Vision Cables
Maximum Length 5 Meters

10M
CEI BITMAXX
Extended Distance
USB3 Vision Cables
Super Speed USB 3.0
Available Lengths
10M, 15M, and 20M

15M

20M

8 Troubleshooting

8.1 Overview

This section provides information for troubleshooting camera installation problems. A few important items from the web site FAQ are repeated here, followed by troubleshooting flow charts enabling the user to pinpoint the problem type.

Lumenera Troubleshooting FAQ on the Web

<https://www.lumenera.com/support/industrial-usb-ethernet/usb-faqs.html#Troubleshooting>

8.2 USB3 Camera FAQ Items

My USB camera is not recognized by the system and not listed in the Device Manager

If the camera does not show up in the Windows Device Manager, the cause could be one of the following:

- If the camera LED remains dark (off), verify that the USB3 cable is not faulty. The camera is normally powered by the USB3 port 5 volt power. Test the camera with another USB3 cable.
- Test the camera by connecting it into another USB3 port, or on another PC. When the camera is detected by host, an entry will appear in the Windows Device Manager – regardless of whether the device driver is loaded on the computer.

Windows Device Manager incorrectly lists the camera, or displays an exclamation mark beside the device

This describes the situation that occurs when the correct device drivers are not loaded to the camera by the operating system. It may occur if the camera is connected to the PC before the software and device drivers have been installed. Lumenera camera device drivers are now signed and compliant with Microsoft requirements, so device drivers should load automatically whenever the camera is connected to a PC where the device drivers are resident.

My image is darker in the corners

This issue known as vignetting happens when the lens image circle used is too small for the camera sensor. Make sure that you use the proper lens/optics for the camera. Your camera's datasheet will state the size of the sensor used so that you can properly match your lens/optics.

Also see [Choosing a Lens with the Correct Image Circle](#) for additional details.

Settings which have an impact on the camera frame rate

There are a few reasons why you cannot get the advertised frame rate:

- The selected exposure time can limit the frame rate. Make sure that the exposure time is $fps < 1/desired\ frame\ rate$.
- There are not enough computer resources to keep up with the current camera data rate. You will need to minimize the resource usage or operate the camera on a faster computer which easily handles the continuous video stream on the USB3 port.



8.3 Using the U3V Device Manager Tool

The Lumenera U3V Device Manager allows quick changes between multiple installed camera drivers. Select the connected camera, select the drive to switch too and click on Switch Protocol.



8.4 Switching a Lumenera camera from LuCam mode to USB3 Vision mode

- Go to the Teledyne Lumenera web site and register your name and password to login and access the download area. [www.lumenera.com]
- Go to */Home/Support/Industrial (USB & Ethernet)/Drivers & Downloads*
- Read the **Important Notes** and use Firefox or Chrome as recommended.
- Download the following three files:

1	LuCam Software and Software Development Kit	
2	USB 3.0 Camera Firmware and Updater	
3	Latest Firmware ZIP file for your camera model	NOTE: DO NOT uncompress the zip file

- **Important:** DO NOT connect the camera to the USB3 port before the two software installations that follow.
- Install the **LuCam Software and Software Development kit** first (file 1). This is required to run the LtUpdater tool.
- Install the **USB 3.0 Camera Firmware and Updater** tool (file 2).
- Connect the Lumenera camera to a USB3 port.
- Run the Lumenera **LtUpdater.exe** tool from the desktop shortcut or from the typical path "*C:\Program Files\Teledyne Lumenera\LtUpdater\LtUpdater.exe*".

- The LtUpdater tool window will show that there is a camera connected in LuCam Mode. If all fields are grayed out, then either the camera is not connected to the computer, is unpowered or is already in USB3 Vision mode.
- Click **Select Packages** and select the camera firmware zip file you have downloaded for your camera model. The LtUpdater tool will automatically show the components within the zip file that will update the camera.
- Click **Update** and wait for confirmation of each updated component. The camera has been programmed with the latest firmware version.
- From the LtUpdater tool Camera Mode field, switch the camera from LuCam mode to USB3 Vision mode.
- Close the LtUpdater tool.
- Cycle the camera power to reset the camera into USB3 Vision mode.
- Start the Spera LT CamExpert application to work with the Lumenera camera as a Spera device.

8.5 Switching a Lumenera camera from USB3 Vision mode to LuCam mode

This procedure describes how to change mode with Spera Lt CamExpert. You can also change it with a USB3 Vision compliant third-party tool using the same features.

- Run CamExpert and select the **Teledyne Lumenera Control** category.

Category	Parameter	Value
Camera Information	Camera Boot Sequence	USB3Vision
Sensor Control	Camera Reset	Press...
I/O Control	<< Less	

- Change the **Camera Boot Sequence** value from *USB3Vision* to *LuCam*.
- Click *Press...* next to **Camera Reset**.
- Cycle the camera power.

The camera is now in LuCam mode. Spera LT CamExpert cannot access the camera.

To return the camera to USB3 Vision mode, follow the procedure from section **Switching a Lumenera camera from LuCam mode to USB3 Vision mode**.

8.6 Troubleshooting Flow Charts

8.6.1 Chart 1

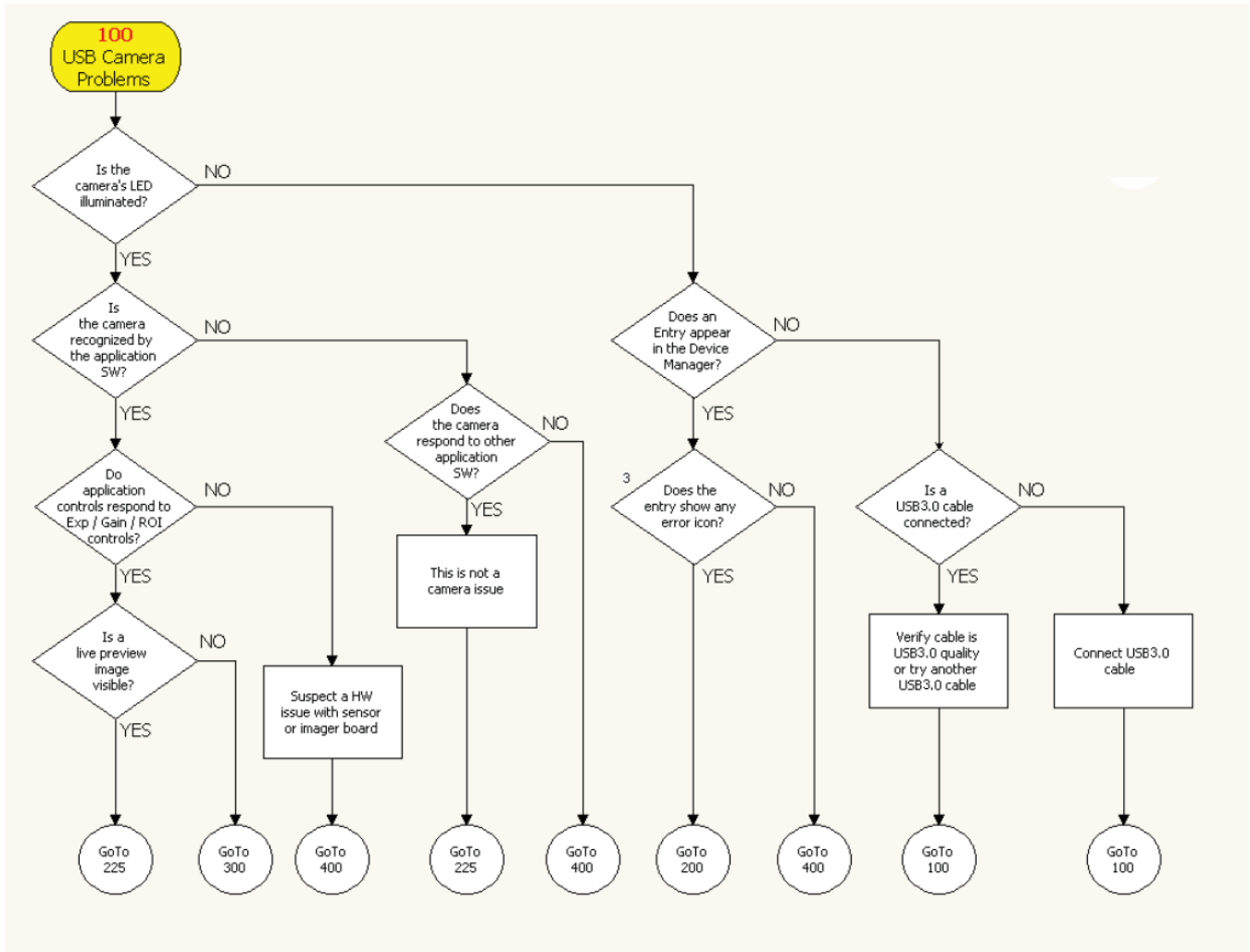

8.6.2 Chart 2

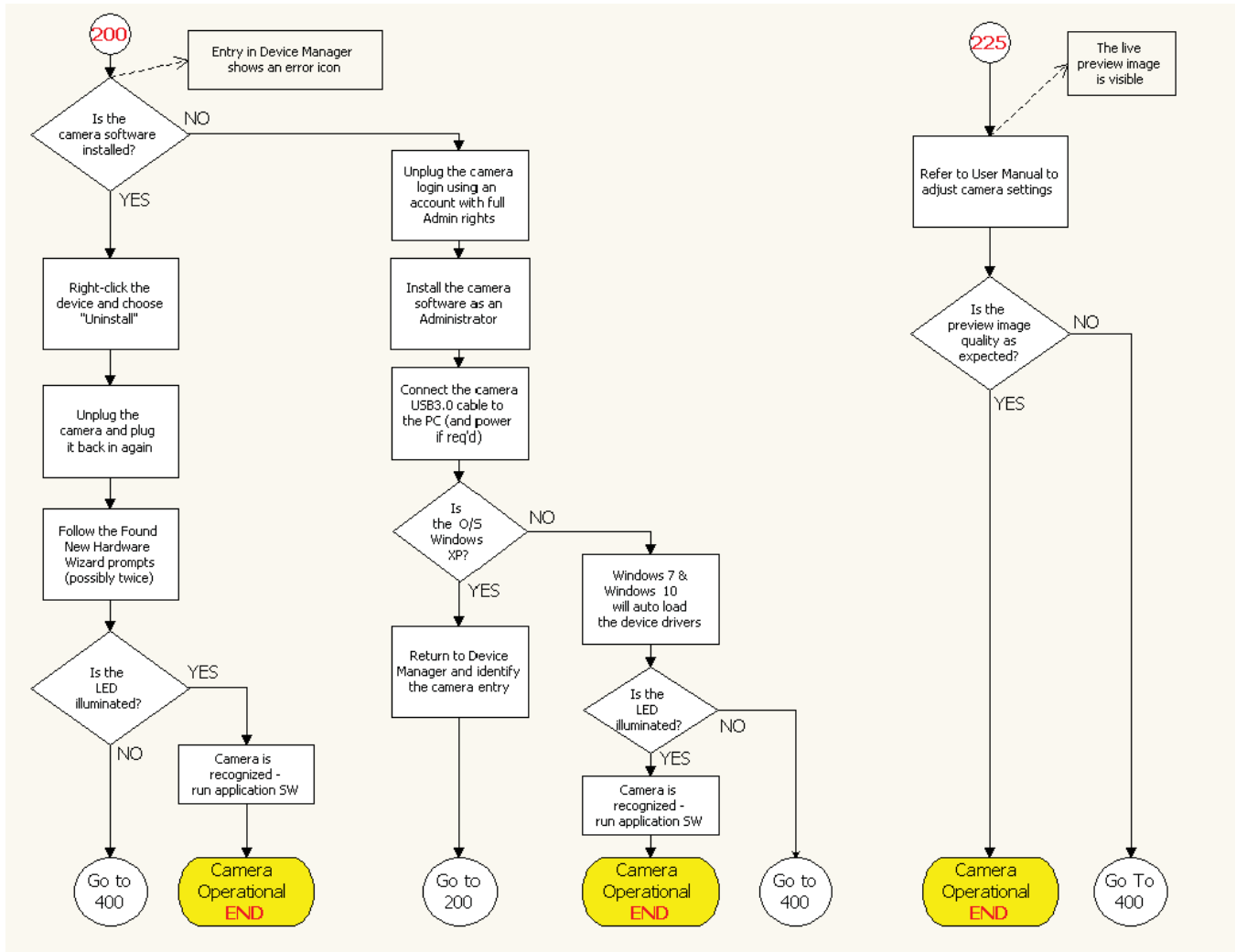

8.6.3 Chart 3

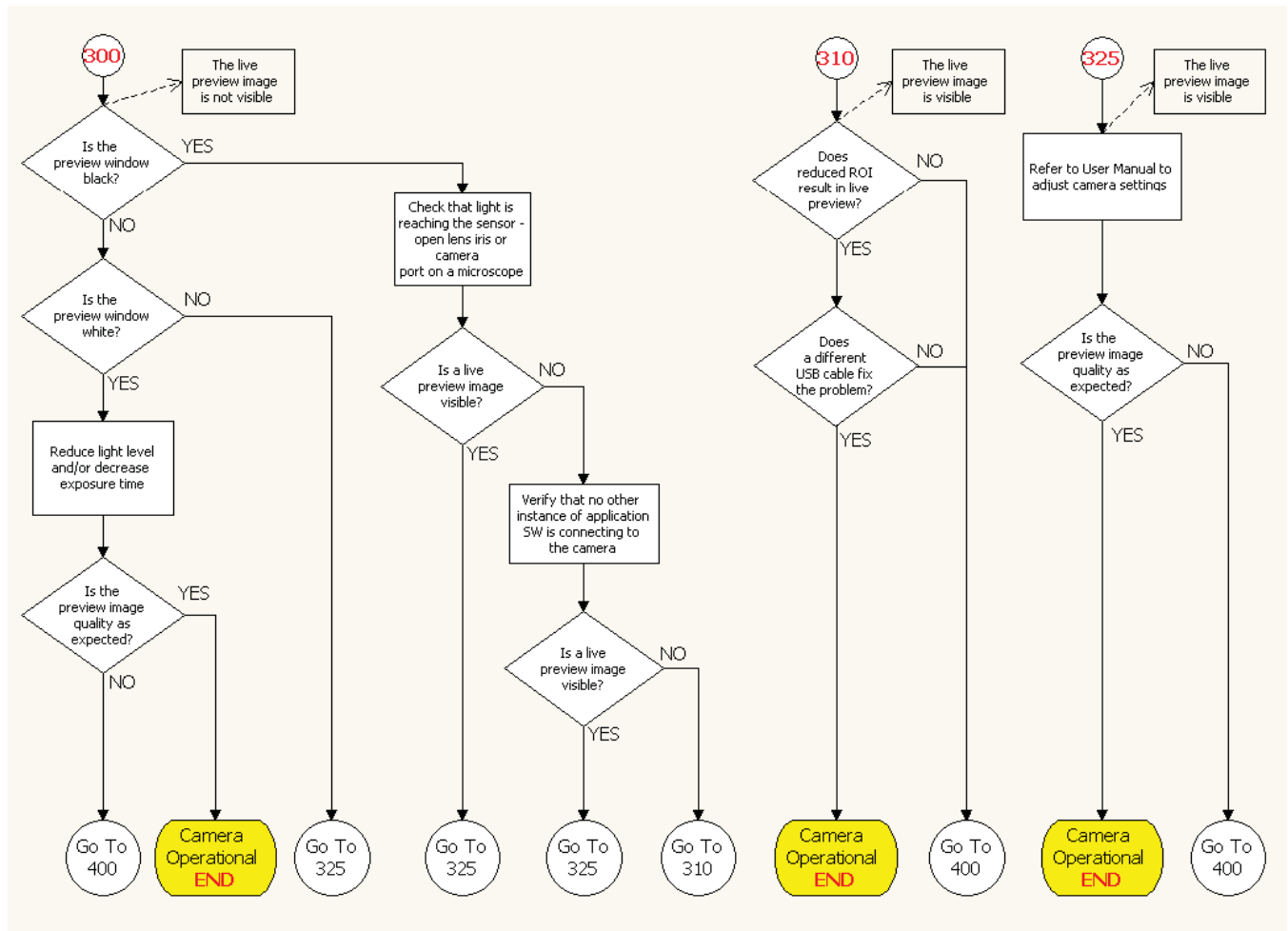

8.6.4 Chart 4

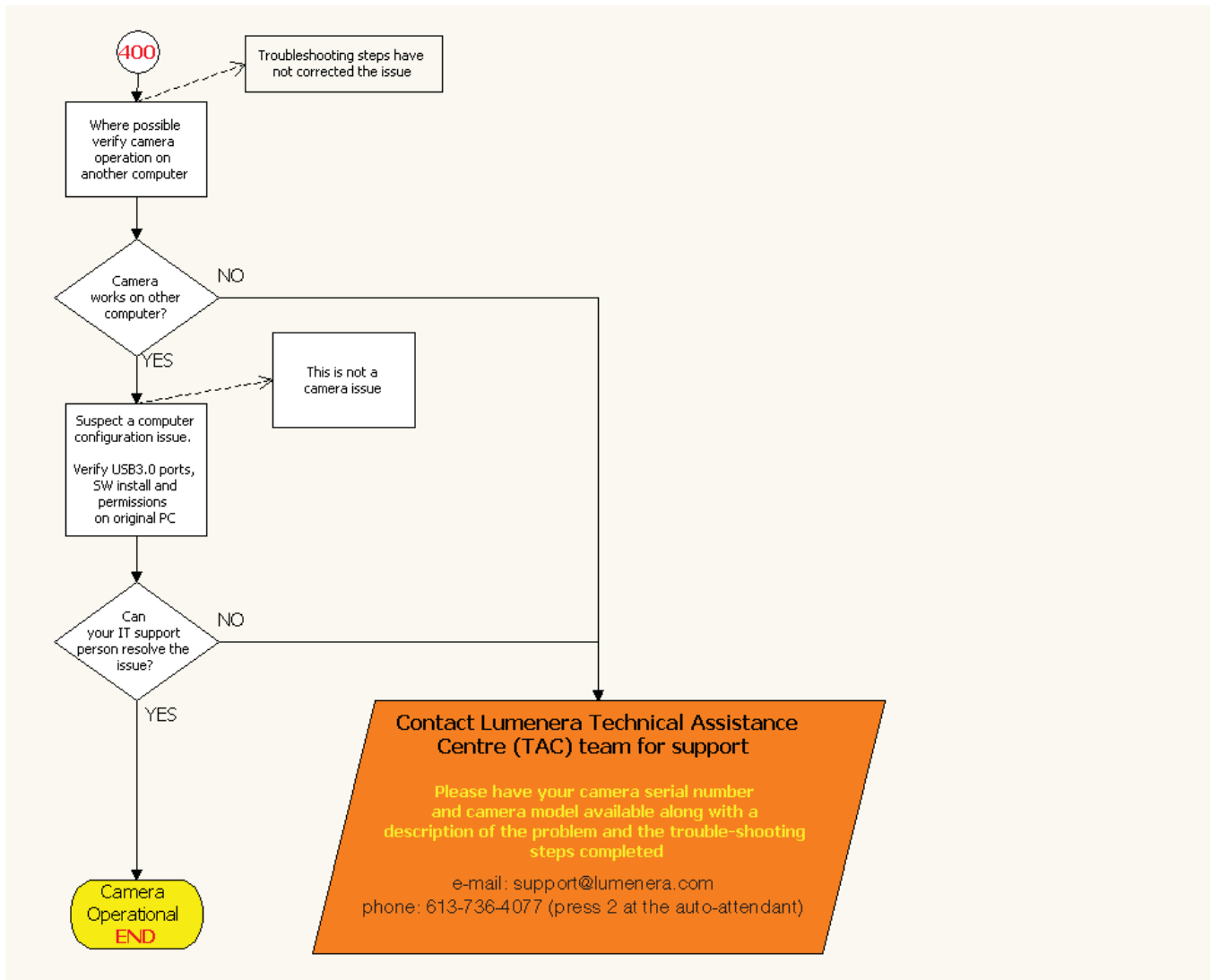

9 Revision History

Revision	Date	Major Change Description
001	February 9, 2021	Preliminary Internal Version
002	June 16, 2021	Addition of new models and related updates. A few corrections to model specifications.

10 Contact Information

10.1 Sales Information

Visit our web site:

<https://www.lumenera.com/>

Sales

Teledyne Lumenera
7 Capella Crt.
Ottawa, Ontario
Canada K2E 8A7
Phone: 1.613.736.4077
Fax: 1.613.736.4071
Email: info@lumenera.com

10.2 Technical Support

Submit any support question or request via our web site:

Technical support form via our web page:
Support requests for imaging product installations,
Support requests for imaging applications

<https://www.lumenera.com/support/about-technical-support.html>

Camera support information

lumenera.support@teledyne.com

Product literature and driver updates